

# P4-30...L100-11

**Model: C12a**

## **en** Assembly and Operating Instructions

### **Sun protection drives with integrated radio receiver 915.3 Mhz**

Important information for:

• Fitters / • Electricians / • Users

Please forward accordingly!

These instructions must be kept safe for future reference.

2010 301 081 0 14/08/2018



## Table of contents

General .....	3
Warranty .....	3
Safety instructions .....	4
Instructions for the user .....	4
Instructions for installation and commissioning .....	4
Intended use .....	6
Assembling and disassembling the plug-in connecting cable .....	6
Assembling the plug-in connecting cable .....	6
Disassembling the plug-in connecting cable for tubular drives dia. 35 .....	7
Disassembling the plug-in connecting cable for tubular drives dia. 45 and dia. 58 .....	8
Installation .....	9
Assembling the drive .....	9
Undoing the mounting pin .....	9
Drive adapter safety catch .....	9
Assembling the drive adapter with safety catch on the drive shaft .....	9
Disassembling the drive adapter with safety catch on the drive shaft .....	10
Assembling and disassembling the drive adapter with screw connection .....	10
Mounting the drive in the tube .....	10
Confirming the drive .....	11
First operation .....	12
Intelligent installation management .....	13
Programming the master transmitter .....	13
Checking that the running direction is correct .....	13
Setting the limit positions .....	14
Extended point to retracted point .....	14
Extended point to retracted stop .....	15
Changing the additional stop behaviour function with the master transmitter .....	15
Changing the set limit positions .....	15
Setting the limit positions with Auto-Install .....	16
Deleting the limit positions .....	17
Intermediate positions I + II .....	18
Programming additional transmitters .....	19
Deleting transmitters .....	19
Overwriting the master .....	20
Local operation with a single button .....	21
Torque detection .....	22
Activating/deactivating the additional fabric untensioning function with the master transmitter .....	22
Activating/deactivating the additional fabric tensioning function with a transmitter .....	22
Disposal .....	22
Maintenance .....	23
Technical data dia. 35 .....	23
Technical data dia. 45 .....	23
Technical data dia. 58 .....	24
Certificate of Suitability .....	24
What to do if...? .....	24
Sample wiring diagram .....	25

## General

These tubular drives are high-quality products with the following features:

- Optimised for sun protection applications
- Suitable for awnings and conservatory shades. Type "+" drives are specially designed for cassette awnings
- Individual, group and central radio control
- No need to run wires to a switch or relay control device
- Any combination of drive and transmitter possible
- Simple to set the limit positions with the transmitter
- Installation without stops is also possible (from extended point to retracted point without stop)
- Two freely selectable intermediate positions can be set
- Flexible radio grouping; can be altered at any time with no need to install/uninstall
- Integrated memo function facilitates easy programming of one or two switching times on daily repeat.
- Automatic detection of limit positions thanks to intelligent electronic system with stop systems
- The limit positions do not have to be reset: Changes in the shading solution are accommodated automatically when using stop systems.
- Considerably reduced stop load, and thus considerably reduced shading solution load
- Smooth operation of the system and the drive increases the service life
- For plug-in connecting cable

Please observe these Assembly and Operating Instructions when installing and setting up the equipment.



The date of manufacture comes from the first four digits of the serial number.

The numbers 1 and 2 indicate the year and the numbers 3 and 4 indicate the calendar week.

Example: 24th calendar week in 2012

Ser. No.:	1224XXXXX
-----------	-----------

### Explanation of pictograms

	<b>CAUTION</b>	CAUTION indicates a hazardous situation which, if not avoided, could result in injury.
	<b>ATTENTION</b>	ATTENTION indicates measures that must be taken to avoid damage to property.
		Denotes user tips and other useful information.

## Warranty

Structural modifications and incorrect installation which are not in accordance with these and our other instructions can result in serious injuries, e.g., crushing of limbs. Therefore, structural modifications may only be carried out with our prior approval and strictly in accordance with our instructions, particularly the information contained in these Assembly and Operating Instructions. Any further processing of the products which does not comply with their intended use is not permitted.

The end product manufacturer and fitter have to ensure that all the relevant current statutory, official and, in particular, EMC regulations are adhered to during utilisation of our products, especially with regard to end product manufacture, installation and customer advice.



## Safety instructions

The following safety instructions and warnings are intended to avert hazards and to prevent property damage and personal injury.

### Instructions for the user

#### General information

- The drive must be disconnected from its power source during cleaning and maintenance and when replacing parts.
- All work, including maintenance and cleaning, on electrical installations as well as other system parts must always be performed by trained technicians, in particular qualified electricians.
- Children from the age of 8 years and persons with reduced physical, sensory or mental capabilities or lack of experience and/or knowledge may use these devices, provided they are supervised or have been instructed in the safe use of the device, and have understood the hazards involved. Children must not play with the device.
- Systems have to be checked regularly by authorised specialists for wear and damage.
- Always put damaged systems out of operation immediately until they are repaired by an authorised specialist.
- Do not operate equipment if people or objects are within the danger zone.
- Observe the danger zone of the equipment during operation.
- Ensure that there is adequate clearance (at least 40 cm) between moving parts and adjacent objects.



#### Caution

#### Safety instructions for avoiding serious injuries.

- **Crushing or shearing points must be avoided or protected.**

### Instructions for installation and commissioning

#### General information

- Observe the safety instructions in IEC 60335-2-97. Please note that this list of safety instructions is not exhaustive, since it would be impossible for the standard to include all sources of danger. For example, the design of the operated product, the way the drive works in the situation it is installed in or even the way the end product is mounted in the end user's place of use cannot be taken into consideration by the drive manufacturer.

If any questions or uncertainties regarding the safety instructions contained in the standard arise, please contact the manufacturer of the part or end product in question.

- All applicable standards and regulations for electrical installation must be complied with.
- All work, including maintenance and cleaning, on electrical installations as well as other system parts must always be performed by trained technicians, in particular qualified electricians.
- Only use spare parts, tools and accessory devices which have been approved by the drive manufacturer.  
Unapproved third-party products or modifications to the system and its accessories represent a risk to your safety and the safety of others. This means that the use of unapproved third-party products, or modifications which have not been agreed with or approved by us, are prohibited. We do not accept liability for damage or injury arising from such actions.
- Position switch with OFF presetting within sight of the driven product, but away from moving parts, at a height of over 1.5 m. This must not be publicly accessible.
- Permanently mounted control devices must be positioned where they can be seen.
- Rated torque and duty cycle must be suitable for the requirements of the driven product.  
Technical data - rated torque and service life can be found on the type plate of the tubular drive.

- Hazardous moving parts of the drive must be installed at a height of over 2.5 m above floor level or any other surface from which the drive can be accessed.
- To ensure safe operation of the system after commissioning, the limit positions must be correctly set/programmed in.
- Drives with a S05RN-F or O5RN-F connecting cable may be used both indoors and outdoors.
- To connect the drive to the driven part, solely mechanical accessory components made by the drive manufacturer from the current product catalogue may be used. The components must be installed in accordance with the manufacturer's instructions.
- If the drive is used for shading solutions in a specially marked area (e.g., escape routes, hazard zones, safety areas), compliance with all applicable regulations and standards must be ensured.



### **Caution**

#### **Safety instructions for avoiding serious injuries.**

- **When electrical or electronic equipment and units are operated, certain components, e.g., the power supply unit, are live. Physical injuries or damage to property can result in the event of unauthorised interventions or failure to heed warnings.**
- **Be careful when touching the tubular drive, as it heats up during operation for technical reasons.**
- **Before installation, shut down all lines and control devices that are not essential for operation.**
- **Crushing or shearing points must be avoided or protected.**
- **When installing the drive, all-pole disconnection from the mains with a contact gap of at least 3 mm per pole must be provided (IEC 60335).**
- **If the mains connecting cable is damaged, it may only be replaced by the manufacturer. If the drive has a plug-in connecting cable, it must be replaced with the same type of mains connecting cable, which is available from the drive manufacturer.**

### **Attention**

#### **Safety instructions for avoiding property damage.**

- **Ensure that there is adequate clearance between moving parts and adjacent objects.**
- **The drive must not be carried by the mains connecting cable.**
- **All latching connections and fastening screws on the brackets must be checked to ensure that they are secure.**
- **Ensure that nothing rubs against the tubular drive, such as shading solution attachments, screws, etc.**



## Intended use

The type of tubular drive described in these instructions is intended solely for the operation of awnings and conservatory shades. It may only be used in networked systems if all the individual drives are exactly synchronised and reach the limit positions at the same time.

When mounting connection parts on the drive dia. 35 mm PXX/XX, only use screws EJOT Delta PT 40x12 WN 5454 Torx (9900 000 545 4).

For roller shutter applications, please use only the types of tubular drive designed for this purpose.

This type of tubular drive is designed for use in single systems (one drive per barrel).

The tubular drive must not be used in potentially explosive areas.

The connecting cable is not suitable for transporting the drive. Always carry the drive by the housing tube.

Other applications, uses and modifications are not permitted in order to protect the safety of the users and others, since these actions can impair the system's safety and carry the risk of personal injury and property damage. The drive manufacturer does not accept liability for damages or injury arising from such actions.

Always observe the information in these instructions when operating or repairing the system. The drive manufacturer does not accept liability for damage or injury resulting from improper usage.

## Assembling and disassembling the plug-in connecting cable

### Assembling the plug-in connecting cable

Insert the **dead** connecting cable into the drive head until the locating lug clicks into place in the drive. If necessary, use a suitable flathead screwdriver to assist with insertion. Set the screwdriver into one of the two plug grooves provided for this purpose.

Check that the cable is properly engaged.

**C+plug**

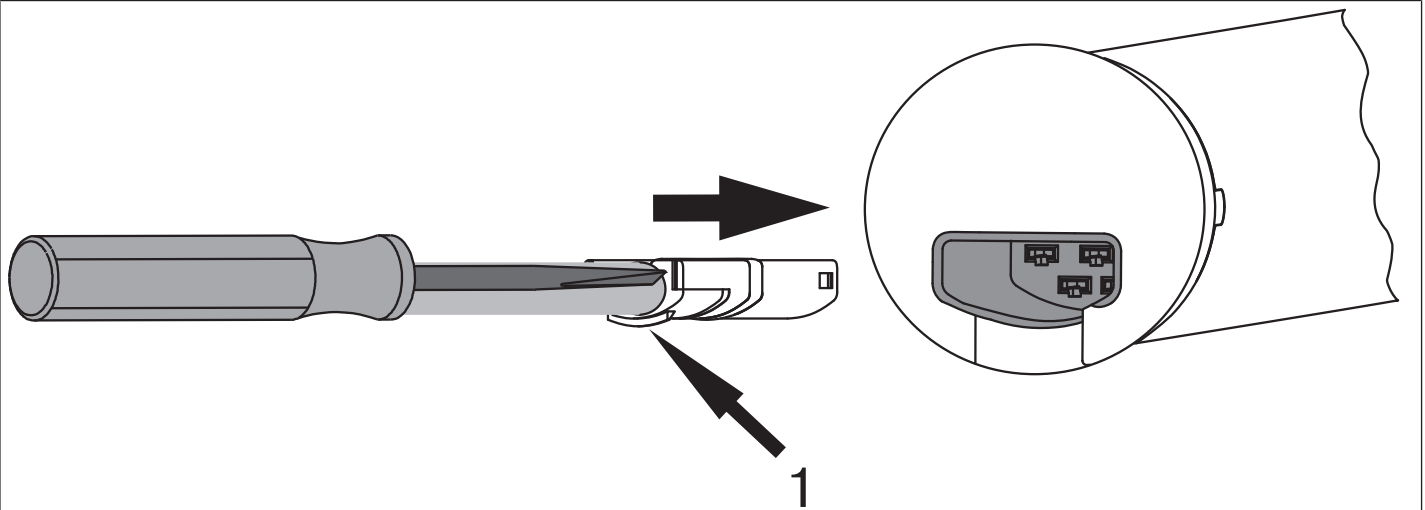

1 = locating lug

## Disassembling the plug-in connecting cable for tubular drives dia. 35.



### Caution

Prior to disassembly, the power supply to the connecting cable must be disconnected.

Insert a suitable flathead screwdriver between the locating lug and the snap-in pin, so that the snap-in pin releases the locating lug from the plug.

Now you can pull out the connecting cable along with the flathead screwdriver.

dia. 35

**C+plug**

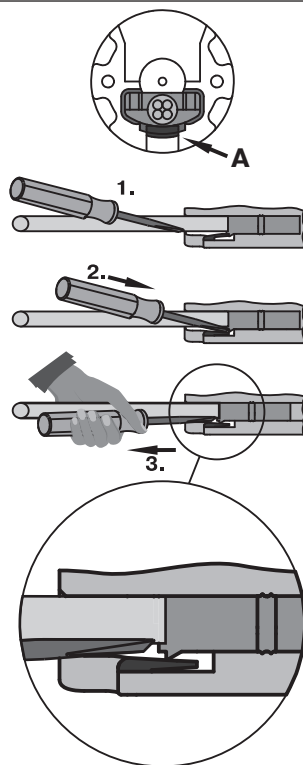

A = snap-in pin



## Disassembling the plug-in connecting cable for tubular drives dia. 45 and dia. 58

 **Caution**  
Prior to disassembly, the power supply to the connecting cable must be disconnected.

Insert a suitable flathead screwdriver right into the recess of the locating latch, so that the latch releases the locating lug from the plug.

Now you can pull out the connecting cable along with the flathead screwdriver.

dia. 45 and dia. 58

**C+plug**

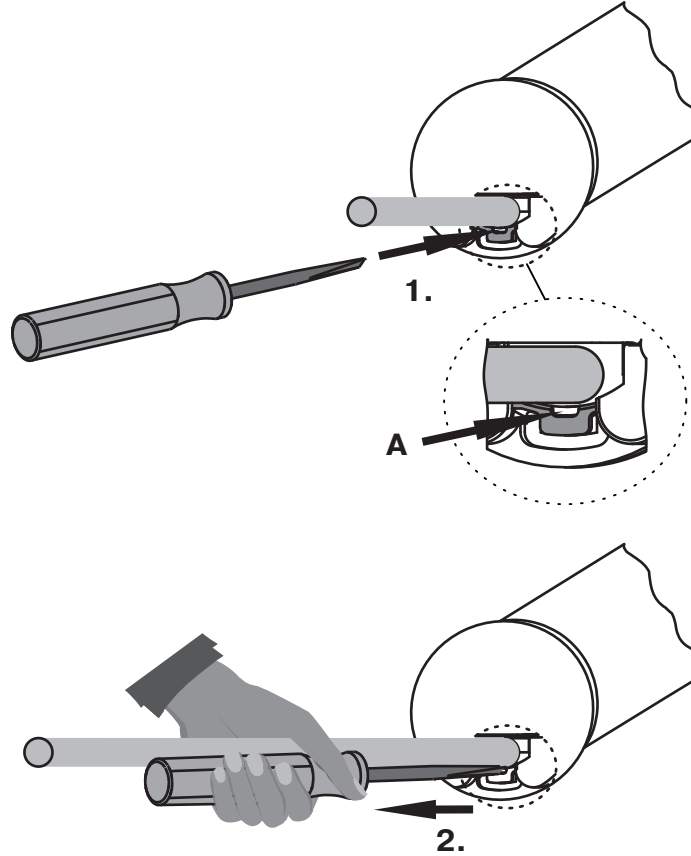

A = locating latch



## Installation

### Assembling the drive

#### Attention

To connect the drive to the driven part, solely mechanical accessory components made by the drive manufacturer from the current product catalogue may be used.

Prior to mounting, the fitter must ensure that the masonry and the system being motorised are sufficiently robust (drive torque plus weight of the shading solution).



#### Caution

Electrical connections may only be carried out by a qualified electrician. Prior to assembly, the power supply must be disconnected and secured. Please give the enclosed connection information to the responsible electrical contractor.

These drives cannot be operated with conventional switching elements (switches, timers and the like).

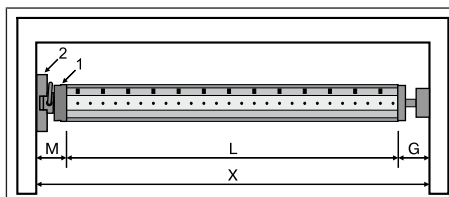

Calculate the space required at the side (M) by measuring the drive head (1) and wall bracket (2). The clear dimension of the box (X) minus the space required at the side (M) and idler (G) gives the length (L) of the barrel:  $L = X - M - G$ .

The space required at the side (M) varies depending on the combination of drive and wall bracket.

Then mount the wall bracket and idler. Ensure that the barrel is aligned at right angles to the wall and that sufficient axial play is allowed for the mounted system.

### Undoing the mounting pin

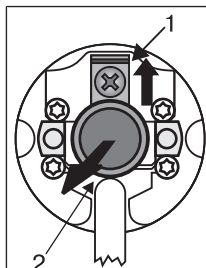

When pushed in, the mounting pin (2) locks automatically. To undo the mounting pin (2), push the tab washer (1) upwards and pull out the mounting pin (2).

### Drive adapter safety catch

#### Assembling the drive adapter with safety catch on the drive shaft

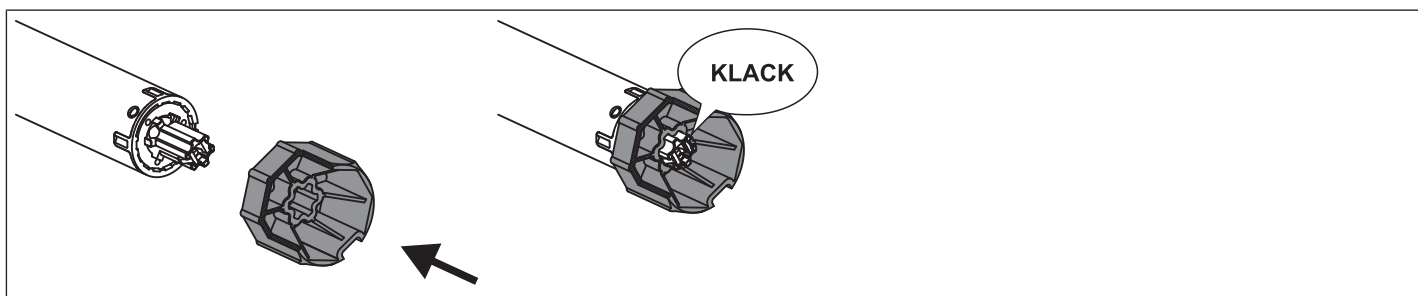

## Disassembling the drive adapter with safety catch on the drive shaft

Disassembly with disassembly tool, Item no. 4930 300 606 0

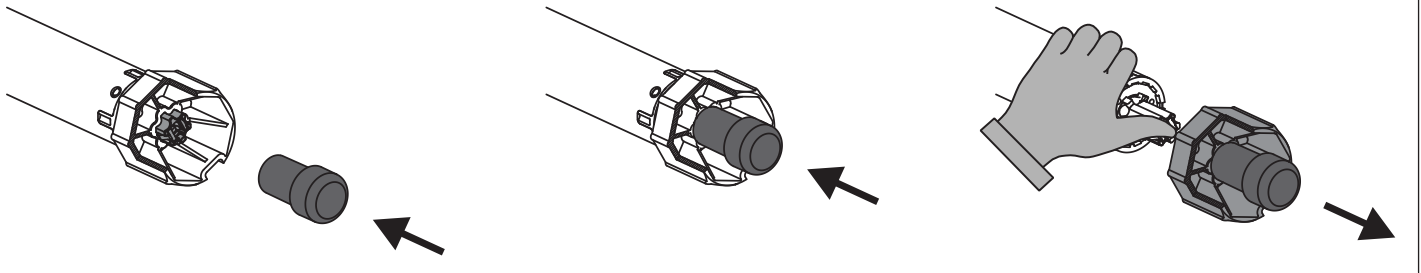

Disassembly with long nose pliers

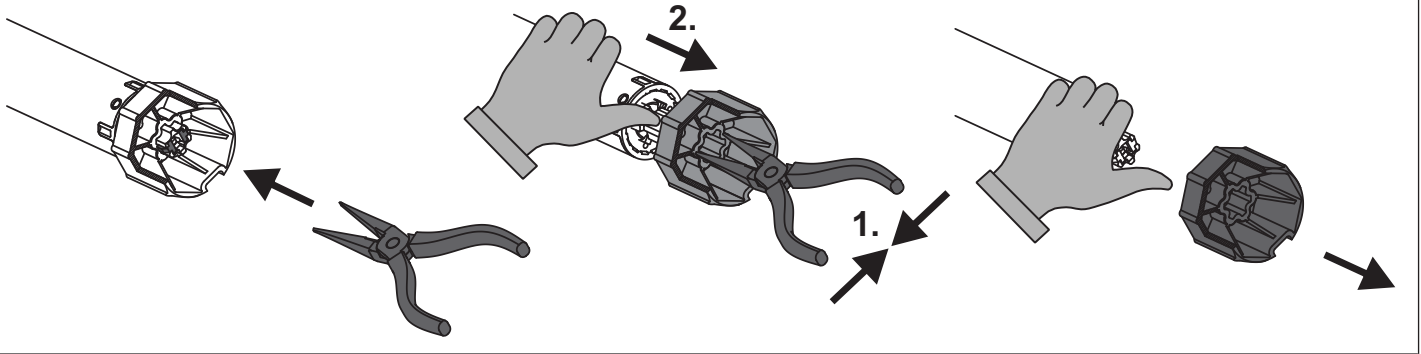

## Assembling and disassembling the drive adapter with screw connection

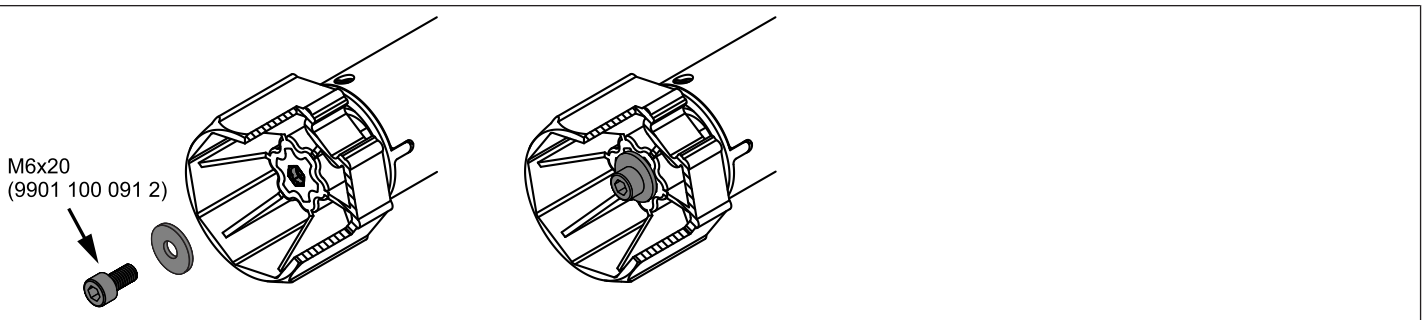

## Mounting the drive in the tube

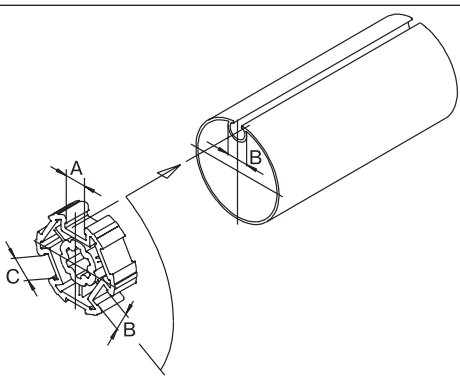

### For profile tubes:

In the case of some drive adapters, tolerances of the groove widths in different barrels can be offset by rotating the drive adapter into a different groove recess. These groove recesses have different sizes and allow the drive to fit exactly.

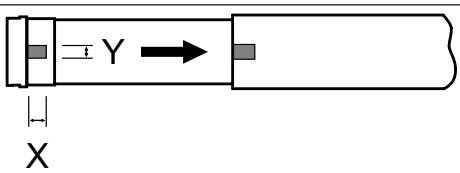

### For round shafts:

Measure the lug of the thrust ring (X, Y). Then notch the tube on the motor side, so the lug of the thrust ring can also be pushed into the shaft. There must be no play between the lug of the thrust ring and the shaft.

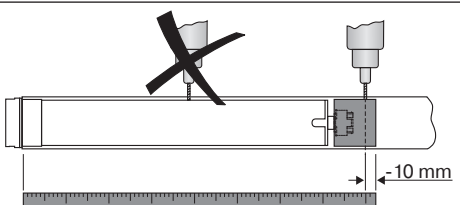

To ensure secure torque transmission for round shafts, we recommend screwing the drive adapter to the shaft (see the table below).

**Attention! When drilling into the barrel, never drill near the tubular drive!**

Size of drive [mm]	Drive adapter	Torque max. [Nm]	Fastening screws (4 units)
dia. 35-dia. 45	All	Up to 50	Self-tapping screw dia. 4.8 x 9.5 mm
dia. 58	Aluminium drive adapter	Up to 120	Countersunk screw M8 x 16 mm
dia. 58	diecast drive adapter	Up to 120	Self-tapping screw dia. 6.3 x 13 mm

We also recommend screwing the idler to the barrel.

### Attention

**Do not hammer the tubular drive into the tube or drop it into the barrel!**



Assemble the tubular drive with the relevant ring (1) and drive adapter (2). If the ring has several grooves, select the groove which is a perfect fit and push the ring (1) onto the thrust ring.

Insert the tubular drive with the pre-assembled ring (1) and drive adapter (2) into the tube to achieve a form fit. Ensure that the ring and drive adapter are secure in the tube.

Mount the assembled unit comprising barrel, tubular drive and idler on the box and secure the drive with a split or spring pin according to the type of wall bracket fixing.

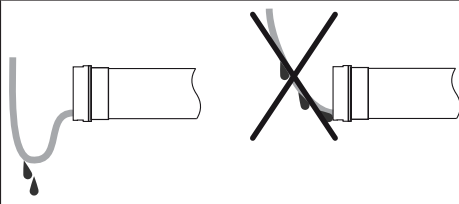

### Lay the connecting cable





Lay the connecting cable up to the tubular drive, and fix. The connecting cable and any antennae must not project into the winding chamber. Cover any sharp edges.

### Confirming the drive

The drive confirms each programming and deletion action. The tubular drive does this through a small movement that can be perceived (audibly) as "clicking" or (visually) as "shifting".

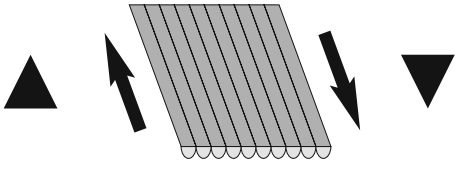
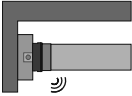
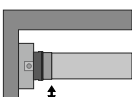
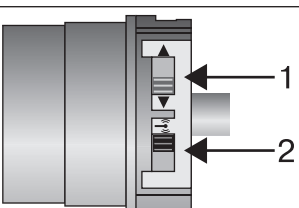

## First operation

Explanation of symbols	
	Retract button
	STOP button
	Extend button
	Programming button
	
	The tubular drive clicks to confirm (One or more times)
	The tubular drive shifts to confirm (One or more times)
	1 = direction switch 2 = radio switch

### Attention

The tubular drives are designed for short-time operation. An inbuilt thermal protection switch prevents overheating of the tubular drive. During commissioning (long drop distance or long running time), the thermoswitch may trigger. The drive will switch off. After a short cooling-down period, the system is ready for operation again.

The drive does not achieve its full duty cycle until it has cooled to ambient temperature. Avoid a situation where the thermal protection switch cuts in repeatedly.

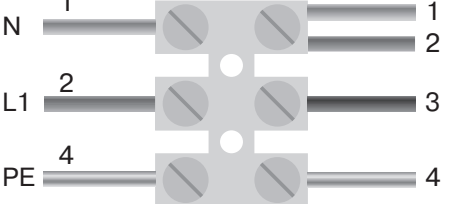
<p>230V AC / 50 Hz </p> 	<h3>Connecting the tubular drive</h3> <p>Connect the tubular drive to the power supply.</p>				
<table border="1" style="width: 100%;"> <tr> <td>1 = blue</td> <td>3 = black</td> </tr> <tr> <td>2 = brown</td> <td>4 = green-yellow</td> </tr> </table>	1 = blue	3 = black	2 = brown	4 = green-yellow	
1 = blue	3 = black				
2 = brown	4 = green-yellow				
	<h3>Readying the tubular drive for programming</h3> <p>Readying the tubular drive for programming by switching on the power</p> <ul style="list-style-type: none"> <li>▸ Switch on the power.</li> <li>▸ The tubular drive is ready to programme for 3 minutes</li> </ul>				

**i** If several tubular drives are to be connected in parallel, you can deactivate the programming mode on one tubular drive by switching the radio switch to the outside position after turning the power on.

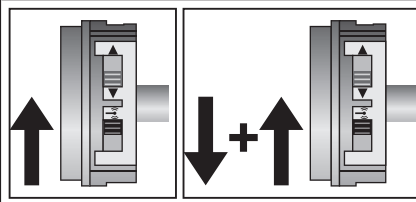

### Readying the tubular drive for programming with the radio switch

Switch the radio switch to the inside position. If the radio switch is already in this position, switch it to the outside and back to the inside position.

- ▶ The tubular drive is ready to programme for 3 minutes

## Intelligent installation management

### Limit position status indicator

A brief stopping and restarting indicates that no limit position has been set in that direction of movement.

### Completion of installation following automatic setting of limit positions

The drive saves the limit position permanently once the upper limit position is reached 3 times in succession. Installation is then complete. If the limit position is set above a point, this is stored permanently.

## Programming the master transmitter

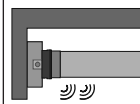

Press the programming button for 3 seconds when it is ready to programme.

- ▶ The tubular drive acknowledges.
- ▶ The programming process is now complete.



**If a transmitter is already programmed on the receiver, press the programming button for 10 seconds.**

## Checking that the running direction is correct

There are 2 ways to change the direction of rotation:

- Changing direction of rotation via rotation direction switch
- Changing direction of rotation via master transmitter

## Changing direction of rotation via rotation direction switch

Press the UP or DOWN button

- ▶ The shading solution runs in the desired direction
- ▶ The running direction is OK.

If the shading solution runs in the wrong direction, the running direction must be changed. Proceed as follows:

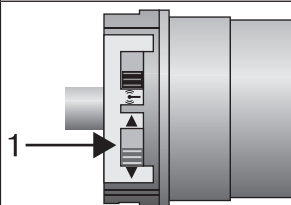
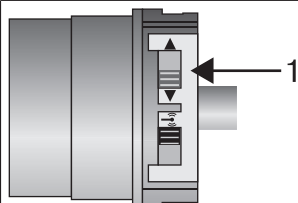

Switch the direction switch (1) to the opposite position.

- ▶ The running direction will now have changed.
- ▶ Check the running direction again.



## Changing direction of rotation via master transmitter



**It is only possible to change the direction of rotation if no limit position has been set.**

Press the UP or DOWN button

- The shading solution runs in the desired direction.
- The running direction is OK.

If the shading solution runs in the wrong direction, the running direction must be changed. Proceed as follows:

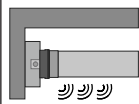

First press the programming button and, within the next 3 seconds, press both the UP and DOWN buttons for 3 seconds.

- The tubular drive acknowledges.

Check the running direction again.

## Setting the limit positions



**The limit positions can only be set with the master transmitter. The shutter direction must be correct. When setting the limit positions, the tubular drive runs in dead-man mode and limit position status indicator. The extended limit position must always be set first. If the tubular drive switches off prematurely while extending/retracting, due to an obstruction, the obstruction can be cleared by extending/retracting the screen and removing the obstruction. The upper limit position can be set by extending/retracting again.**

### There are 2 ways to set the limit positions:

- Extended point to retracted point
- Extended position to retracted stop

The limit position becomes fixed after the tubular drive has turned off **automatically** in the desired position three times.

#### Extended point to retracted point



**There is no shading solution length adjustment with this limit position setting.**

▼		Open to the desired extended limit position.
● + ▼		Press the programming button and, within 3 seconds, also press the extend button and hold the two buttons down. <ul style="list-style-type: none"> <li>▸ The tubular drive acknowledges.</li> </ul>
▲		Then close to the desired retracted limit position.
● + ▲		Press the programming button and, within 3 seconds, also press the retract button and hold the two buttons down. <ul style="list-style-type: none"> <li>▸ The tubular drive acknowledges.</li> <li>▸ The limit positions are now set.</li> </ul>

### Extended point to retracted stop

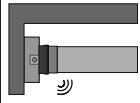
▼		Open to the desired extended limit position.
● + ▼		Press the programming button and, within 3 seconds, also press the extend button and hold the two buttons down. <ul style="list-style-type: none"> <li>▷ The tubular drive acknowledges.</li> </ul>
▲		Then retract to the permanent stop. <ul style="list-style-type: none"> <li>▷ The tubular drive switches off automatically.</li> <li>▶ The limit positions are now set.</li> </ul>

### Changing the additional stop behaviour function with the master transmitter

On delivery, the 35 diameter drive types have a reduced stop behaviour, and the 45 diameter and 58 diameter drive types have an increased stop behaviour.

Proceed as follows to change the stop behaviour:

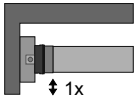
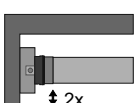
<p><b>i</b> The "to retracted stop" limit position must be set in order to adjust the stop behaviour. The stop behaviour can be changed during the first 3 runs towards the stop.</p>		
▲		Press and hold the retract button in order to retract the sun protection system.
▲ + ●		While retracting, <b>also</b> press the programming button for at least 3 seconds until the tubular drive switches off automatically at the stop, and continue holding the two buttons down until confirmation is complete.
 <p>↓ 1x</p> <p>or</p>  <p>↓ 2x</p>		<p>The tubular drive acknowledges.</p> <p>1 shift = reduced stop behaviour                  2 shifts = increased stop behaviour</p>

### Changing the set limit positions



Once set, the limit positions can only be changed with the master transmitter.

#### 1) Shortening the range of travel (the desired limit position is located inside the current range of travel)

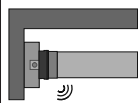



▲ / ▼		Open/close to the desired new limit position.
● + ▲ / ● + ▼		Press the programming button and, within 3 seconds, also press the extend button for the extended limit position or the retract button for the retracted limit position and hold the two buttons down. <ul style="list-style-type: none"> <li>▷ The tubular drive acknowledges.</li> <li>▶ The new limit position is now saved.</li> </ul>



## 2) Extending the range of travel (the desired limit position is located outside the current range of travel)

### Attention

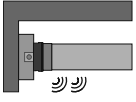
When both or individual limit positions are deleted, all the other set functions (intermediate position I, intermediate position II) are deleted as well.

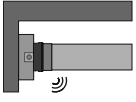
		<p>Open/close to the limit position in the direction in which you wish to extend the range of travel.</p>
		<p>Press the programming button and, within the next 3 seconds, press the STOP button at the same time and hold the two buttons down for 10 seconds.</p> <ul style="list-style-type: none"> <li>▶ The tubular drive acknowledges.</li> <li>▶ The limit position is now deleted.</li> </ul>
		<p>Open/close to the desired new limit position.</p>
		<p>Press the programming button and, within 3 seconds, also press the extend button for the extended limit position or the retract button for the retracted limit position and hold the two buttons down.</p> <ul style="list-style-type: none"> <li>▶ The tubular drive acknowledges.</li> <li>▶ The new limit position is now saved.</li> </ul>

## Setting the limit positions with Auto-Install

### Intelligent installation management

#### Limit position status indicator

A brief stopping and restarting indicates that no limit position has been set in that direction of movement.

#### Completion of installation following automatic setting of limit position "Stop"

The drive saves the limit position "Stop" permanently once the it has been reached 3 times in succession. Installation is then complete.

### Setting the limit positions

There are several ways to set the limit positions:

- Start point to retracted stop
- Auto point to retracted stop (only with articulated-arm awnings)



**These tubular drives are designed for short-time operation (for the operating mode, please see technical data).**

**The number of cycles an awning is capable of depends on the barrel diameter and awning extension.**

**The drive running time is cut short if the drive has not cooled down fully after the previous use.**



### Start point to retracted stop

▼	<p>Move the sun protection system to the desired maximum projection. This must be at least 2.5 revolutions of the barrel away from the retracted limit position. At this time, it is still possible to amend the position.</p>
▲	<p>Then, retract the sun protection system <b>without interruption</b> until the tubular drive switches off automatically.</p> <p>Installation is now complete; electronic limit switching has saved the limit positions. As a final check, run the sun protection system to the two limit positions again.</p> <p>To ensure that the limit position is reliably detected and the sun protection system is fully closed, the tubular drive pulls the cloth slightly more strongly during the installation.</p>

### Auto point to retracted stop (only with articulated-arm awnings)

<p><b>Attention</b> Ensure that the cloth is not wound up the wrong way by the barrel.</p>	
▼	<p>Extend the articulated-arm awning until the articulated arms are fully protracted and the cloth is lying loosely over them.</p>
▲	<p>Then, retract the articulated-arm awning <b>without interruption</b> until the tubular drive switches off automatically.</p> <p>Installation is now complete; electronic limit switching has saved the limit positions. As a final check, run the sun protection system to the two limit positions again.</p> <p>To ensure that the limit position is reliably detected and the sun protection system is fully closed, the tubular drive pulls the cloth slightly more strongly during the installation.</p>

### Deleting the limit positions



<p><b>Attention</b> When both or individual limit positions are deleted, all the other set functions (intermediate position I, intermediate position II) are deleted as well.</p>	
	<p>Once set, the limit positions can only be deleted with the master transmitter.</p>

### Deleting individual limit positions

	<p>Open/close to the limit position to be deleted.</p>
	<p>Press the programming button and, within the next 3 seconds, press the STOP button at the same time and hold the two buttons down for 10 seconds.</p> <ul style="list-style-type: none"> <li>▶ The tubular drive acknowledges.</li> <li>▶ The limit position is now deleted.</li> </ul>

## Deleting both limit positions

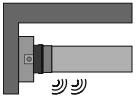

**i** Any additional functions that may have been set are deleted at the same time, or are reset to the factory default settings.

	<p>Open/close the shading solution to a point between the limit positions.</p>
	 <p>Press the programming button and, within the next 3 seconds, press the STOP button at the same time and hold the two buttons down for 10 seconds.</p> <ul style="list-style-type: none"> <li>▶ The tubular drive acknowledges.</li> <li>▶ The limit positions are now deleted.</li> </ul>

## Intermediate positions I + II

**i** The intermediate positions I + II are freely selectable positions for the shading solution between the two limit positions. Each travel button can be assigned one intermediate position. Both limit positions must be set before an intermediate position is set.

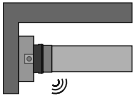

### Setting the desired intermediate position

	<p>Open/close the shading solution to the desired intermediate position.</p>
	 <p>Press the STOP button and, within 3 seconds, also press the desired travel button and hold the two buttons down.</p> <ul style="list-style-type: none"> <li>▶ The tubular drive acknowledges.</li> <li>▶ The intermediate position is now saved.</li> </ul>

### Travelling to the desired intermediate position

	<p>Press the travel button for the desired intermediate position twice within one second.</p> <ul style="list-style-type: none"> <li>▶ The curtain runs to the intermediate position assigned to the travel button.</li> </ul>
---	--

### Deleting the desired intermediate position

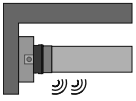
	<p>Move the shading solution to the intermediate position that is to be deleted.</p>
	 <p>Now press the STOP button and, within 3 seconds, also press the travel button assigned to the intermediate position and hold the two buttons down.</p> <ul style="list-style-type: none"> <li>▶ The tubular drive acknowledges.</li> <li>▶ The intermediate position is now deleted.</li> </ul>

## Programming additional transmitters

**i** In addition to the master transmitter, up to 15 further transmitters can be programmed in the tubular drive. Before programming a radio controlled Sun-Wind-Sensor, the limit positions must be programmed.

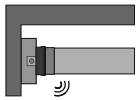
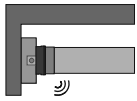
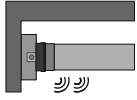
●		Press the programming button of the master transmitter for 3 seconds. ▷ The tubular drive acknowledges.
●		Now press the programming button of a new transmitter which has not yet been programmed in the tubular drive for 3 seconds. Doing so activates the programming mode of the tubular drive for a new transmitter for 3 minutes. ▷ The tubular drive acknowledges.
●		Now press the programming button of the new transmitter you wish to program again for 3 seconds. ▷ The tubular drive acknowledges. ▶ The new transmitter has now been programmed.

## Deleting transmitters

### Deleting individual transmitters

**i** The programmed master transmitter cannot be deleted. It can only be overwritten (see Programming the master transmitter [▶ 13]).

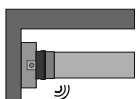
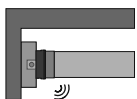
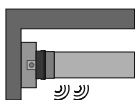
●		Press the programming button on the master transmitter for 3 seconds. ▷ The tubular drive acknowledges.
●		Now press the programming button of the transmitter to be deleted for 3 seconds. ▷ The tubular drive acknowledges.
●		Then press the programming button of the transmitter to be deleted again for 10 seconds. ▷ The tubular drive acknowledges. ▶ The transmitter is now deleted from the tubular drive.

### Deleting all transmitters (except the master transmitter)

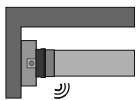
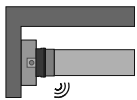
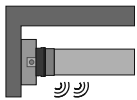
●		Press the programming button on the master transmitter for 3 seconds. ▷ The tubular drive acknowledges.
●		Re-press the programming button on the master transmitter for 3 seconds. ▷ The tubular drive acknowledges.
●		Re-press the programming button on the master transmitter for 10 seconds. ▷ The tubular drive acknowledges. ▶ All transmitters (except the master transmitter) are now deleted from the receiver.





## Overwriting the master

There are two ways to overwrite the master:

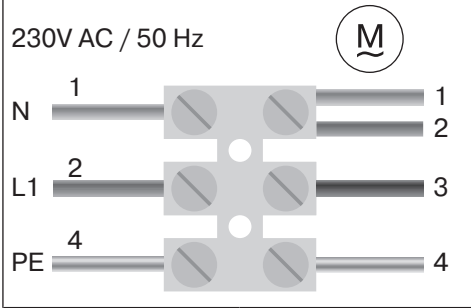

- Ready the tubular drive for programming by switching on the power
- Ready the tubular drive for programming with the radio switch

### Readying the tubular drive for programming by switching on the power

**i** To ensure that the new master transmitter is programmed in the desired tubular drive only, all other tubular drives which are connected to the same power supply must be deactivated from the programming mode. To do so, after switching back on the power, execute a drive or stop command using the transmitter for the given tubular drives or switch the radio switch from inside to outside. If the radio switch is already in this position, switch it to the inside and back to the outside position.

<p>230V AC / 50 Hz</p> 	<p>Switch off the tubular drive power for 5 seconds, then switch it back on.</p> <ul style="list-style-type: none"> <li>▸ The tubular drive is ready to program for 3 minutes.</li> </ul>				
<table border="1"> <tr> <td>1 = blue</td> <td>3 = black</td> </tr> <tr> <td>2 = brown</td> <td>4 = green/yellow</td> </tr> </table>	1 = blue	3 = black	2 = brown	4 = green/yellow	
1 = blue	3 = black				
2 = brown	4 = green/yellow				
	<p>Now press the programming button of the new master transmitter for 10 seconds.</p> <ul style="list-style-type: none"> <li>▸ The tubular drive acknowledges.</li> <li>▸ The new master transmitter has now been programmed and the old master transmitter overwritten.</li> </ul>				

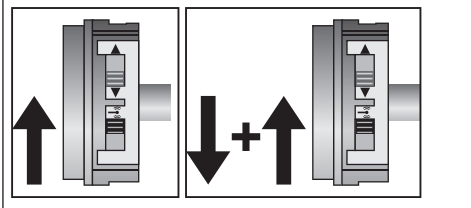
### Readying the tubular drive for programming with the radio switch

	<p>Switch the radio switch to the inside position. If the radio switch is already in this position, switch it to the outside and back to the inside position.</p> <ul style="list-style-type: none"> <li>▸ The tubular drive is ready to program for 3 minutes.</li> </ul>
	<p>Now press the programming button of the new master transmitter for 10 seconds.</p> <ul style="list-style-type: none"> <li>▸ The tubular drive acknowledges.</li> <li>▸ The new master transmitter has now been programmed and the old master transmitter overwritten.</li> </ul>

## Local operation with a single button

### Wiring



**Only use a single button (normally open). Connect one button for each drive. The button must not be operated during the first five seconds after the mains voltage has been switched on.**

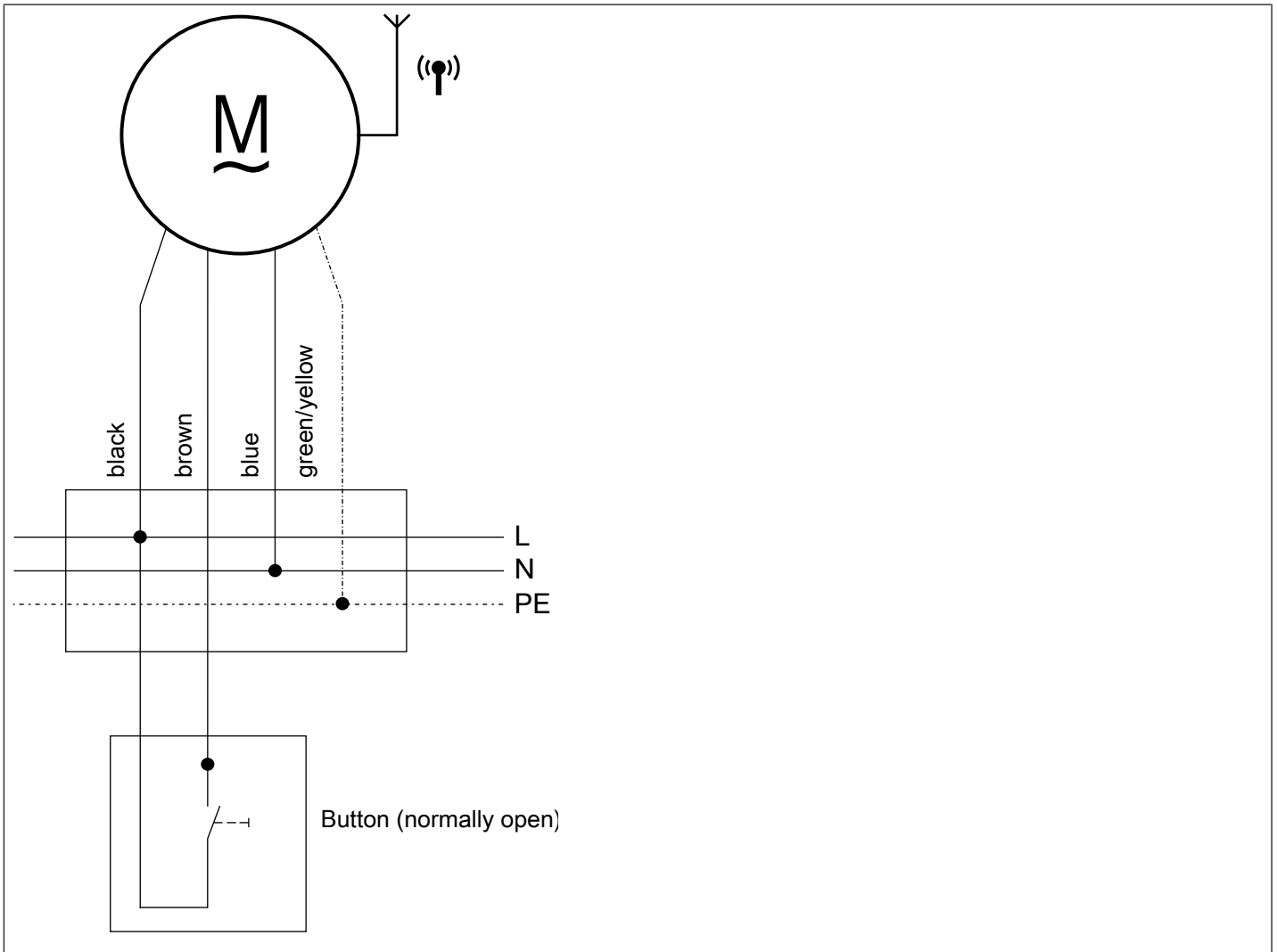

### Button commands

< 1 second	Moves in maintained operation
> 1 second	Moves in dead-man mode
Double-tap < 1 second	Moves to the intermediate position (in alternation if both are programmed)

Operation proceeds in this sequence: "Travel-Stop-Travel-in-the-opposite-direction-Stop".



## Torque detection

A correctly installed tubular drive reacts to extraordinarily large increases in load during operation between the limit positions and thereby prevents an overload of the tubular drive.

### Activating/deactivating the additional fabric untensioning function with the master transmitter

**i** The "to retracted stop" limit position must be set for the fabric untensioning function.

On delivery, the fabric tensioning function is deactivated.

#### Activating/deactivating the fabric untensioning function

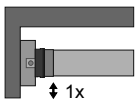
▲		Open the shading solution to the Retract limit position.
● + ■ + ▼		Then press the programming button again, and also the STOP and extend buttons for approx. 3 seconds. <ul style="list-style-type: none"> <li>▶ The tubular drive acknowledges.</li> </ul>

### Activating/deactivating the additional fabric tensioning function with a transmitter

On delivery, the fabric tensioning function is deactivated.

#### Activating the fabric tensioning function

**i** The fabric stretching function is performed in the Extend limit position and at the programmed intermediate position.

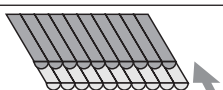
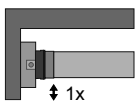
▼		To activate it, move to the Extend limit position.
▲		Now move to the position where the fabric has the desired tension.
● + ■ + ▲		Press the programming button and, within the next 3 seconds, press the STOP and retract buttons at the same time and hold the buttons down for 3 seconds. <ul style="list-style-type: none"> <li>▶ The tubular drive acknowledges.</li> <li>▶ The fabric tensioning function is now active.</li> </ul>

#### Deactivating the fabric tensioning function

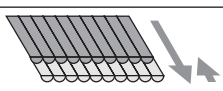
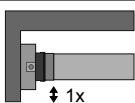
▼		To deactivate it, move to the fabric tensioning limit position.
● + ■ + ▲		Press the programming button and, within the next 3 seconds, press the STOP and retract buttons at the same time and hold the buttons down for 3 seconds. <ul style="list-style-type: none"> <li>▶ The tubular drive acknowledges.</li> <li>▶ The fabric tensioning function is now deactivated.</li> </ul>

## Disposal

This product is made of various materials which must be disposed of properly. Find out about the applicable regulations on recycling or disposal for this product in your country.

The packaging material must be disposed of properly.

## Maintenance

These drives are maintenance-free.

### Technical data dia. 35

Tubular drive	P4-30	P5-20
Model	C12a	
Type	C PSF(+) A	
Rated torque [Nm]	4	5
Output speed [rpm]	30	20
Limit switch range	64 revolutions	
Supply voltage	240 V AC / 50 Hz	
Connected load [W]	110	110
Rated current consumption [A]	0.45	0.45
Operating mode	S2 4 min	
Degree of protection	IP 44	
Min. tube inside diameter [mm]	37	
Frequency	915.3 MHz	
Emission sound pressure level [dB(A)]	≤ 70	

### Technical data dia. 45

Tubular drive	R8-17	R12-17	R20-17	R30-17	R40-17	R50-11
Model	C12a					
Type	C PSF(+) A					
Rated torque [Nm]	8	12	20	30	40	50
Output speed [rpm]	17	17	17	17	17	11
Limit switch range	64 revolutions					
Supply voltage	240 V AC / 50 Hz					
Connected load [W]	100	120	160	210	260	240
Rated current consumption [A]	0.45	0.50	0.70	0.95	1.10	1.00
Operating mode	S2 4 min					
Degree of protection	IP 44					
Min. tube inside diameter [mm]	47					
Frequency	915.3 MHz					
Emission sound pressure level [dB(A)]	≤ 70					



## Technical data dia. 58

Tubular drive	L50-17	L60-11	L60-17	L80-11	L100-11
Model	C12a				
Type	C PSF(+) A				
Rated torque [Nm]	50	60	60	80	100
Output speed [rpm]	17	11	17	11	11
Limit switch range	64 revolutions				
Supply voltage	240 V AC / 50 Hz				
Connected load [W]	300	250	400	310	450
Rated current consumption [A]	1.30	1.05	1.65	1.30	1.95
Operating mode	S2 4 min				
Degree of protection	IP 44				
Min. tube inside diameter [mm]	60				
Frequency	915.3 MHz				
Emission sound pressure level [dB(A)]	≤ 70				

## Certificate of Suitability

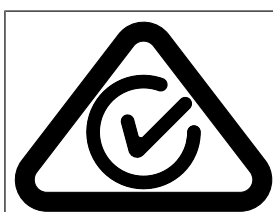

Certificate No.: SAA181406

## What to do if...?

Problem	Remedy
Tubular drive is not functioning.	Program new transmitter.
	Bring transmitter within range of the tubular drive.
	Press drive or stop button on transmitter at least 5 times in the immediate vicinity of the tubular drive.
	Insert batteries correctly or insert new batteries.
	Check electrical connection.
	Thermal protection switch in tubular drive has tripped. Wait until the thermal protection switch in the tubular drive is reactivated.
Shutter direction on tubular drive cannot be set.	Delete limit positions (see Deleting the limit positions) and reset the shutter direction.
Incorrect shutter direction after deleting limit positions.	Change the shutter direction using the master transmitter or the direction switch on the tubular drive.
Tubular drive stops arbitrarily; cannot be restarted in the same direction.	Tubular drive has detected an increase in load. Briefly run the curtain in the opposite direction, then continue in the desired direction.
	Tubular drive is overloaded. Use a higher-torque tubular drive.



Sample wiring diagram

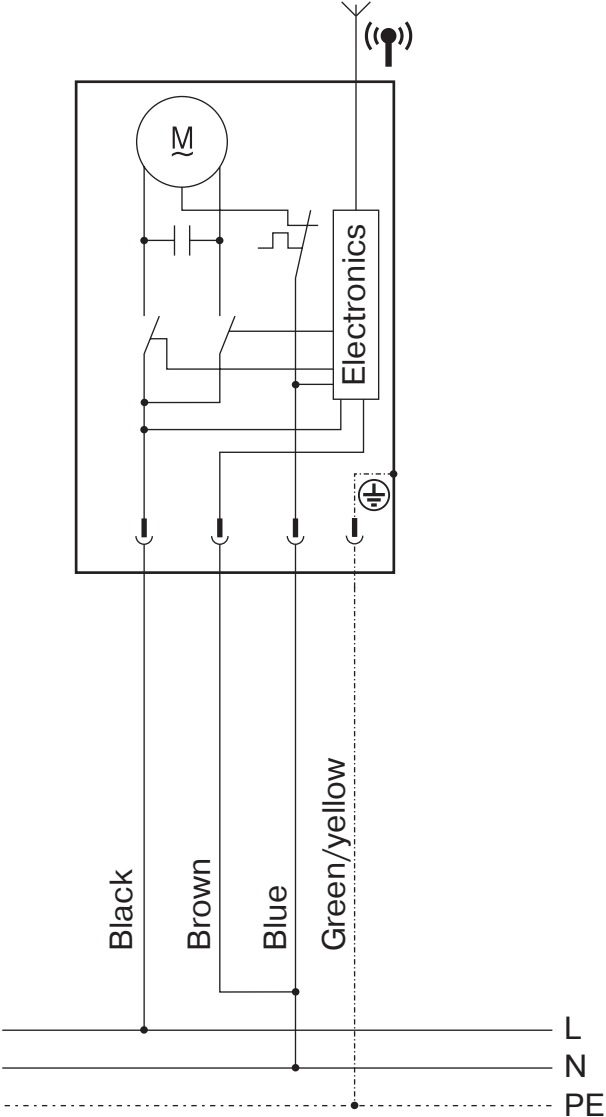







**BECKER**