

# R12-17...R40-17

**Model: C01a**

## **en** Assembly and Operating Instructions

### **Roller shutter drive with integrated radio receiver 915.3 Mhz**

Important information for:

• Fitters / • Electricians / • Users

Please forward accordingly!

These instructions must be kept safe for future reference.

2010 300 570 0d 14/08/2018



## Table of contents

General .....	3
Warranty .....	4
Safety instructions .....	4
Instructions for the user .....	4
Instructions for installation and commissioning .....	4
Intended use .....	6
Assembling and disassembling the plug-in connecting cable .....	6
Assembling the plug-in connecting cable .....	6
Disassembling the plug-in connecting cable for tubular drives dia. 45 and dia. 58 .....	7
Installation .....	8
Assembling the drive .....	8
Undoing the mounting pin .....	8
Drive adapter for obstacle detection .....	8
Drive adapter safety catch .....	9
Assembling the drive adapter with safety catch on the drive shaft .....	9
Disassembling the drive adapter with safety catch on the drive shaft .....	9
Assembling and disassembling the drive adapter with separate drive adapter safety catch .....	9
Assembling and disassembling the drive adapter with screw connection .....	9
Mounting the drive in the tube .....	10
Confirming the drive .....	11
First operation .....	12
Programming the master transmitter .....	13
Checking that the running direction is correct .....	13
Intelligent installation management .....	14
Setting the limit positions .....	14
Upper stop to lower stop .....	14
Upper point to lower point .....	15
Upper stop to lower point .....	15
Upper point to lower stop .....	15
Changing the set limit positions .....	16
Deleting the limit positions .....	16
Intermediate positions I + II .....	17
Programming additional transmitters .....	18
Deleting transmitters .....	18
Overwriting the master .....	19
Local operation with a single button .....	21
Upper anti-freeze mechanism .....	22
Activating/Deactivating upper anti-freeze mechanism .....	22
Obstacle detection .....	22
Fly screen protection function .....	23
Disposal .....	23
Maintenance .....	23
Technical data dia. 45 .....	23
Certificate of Suitability .....	24
What to do if...? .....	24
Sample wiring diagram .....	25

## General

These tubular drives are high-quality products with the following features:

- Optimised for roller shutter operation
- Individual, group and central radio control
- No need to run wires to a switch or relay control device
- Any combination of drive and transmitter possible
- Simple to set the limit positions with the transmitter
- Installation without stops possible (from upper point to lower point)
- Two freely selectable intermediate positions can be set
- Flexible radio grouping; can be altered at any time with no need to install/uninstall
- Automatic detection of the lower limit position when using springs in conjunction with the "drive adapter for obstacle detection"
- Automatic detection of limit positions thanks to intelligent electronic system with stop systems
- Obstacle detection, even when using anti-lifting devices (axle shaft devices)
  - Secure anti-lifting device
  - Slight pressure applied to the roller shutter curtain makes it difficult to raise or reach under it
  - Suitable for rigid aluminium, steel and wooden profiles
- The final positions do not have to be reset: Changes in the shading solution are accommodated automatically when using stop systems.
- Torque control in the up direction prevents damage to the roller shutter in the event of a frozen or blocked shutter
- Anti-freeze mechanism in the upper limit position can be enabled
- Considerably lower stop load, and thus considerably lower shading solution load.
- Smooth operation of the system and the drive increases the service life
- For plug-in connecting cable
- Fly screen protection function

Please observe these Assembly and Operating Instructions when installing and setting the equipment.



The date of manufacture comes from the first four digits of the serial number.

The numbers 1 and 2 indicate the year and the numbers 3 and 4 indicate the calendar week.

Example: 24th calendar week in 2012

Ser. No.:	1224XXXXX
-----------	-----------

### Explanation of pictograms

	<b>CAUTION</b>	CAUTION indicates a hazardous situation which, if not avoided, could result in injury.
	<b>ATTENTION</b>	ATTENTION indicates measures that must be taken to avoid damage to property.
		Denotes user tips and other useful information.



## Warranty

Structural modifications and incorrect installation which are not in accordance with these and our other instructions can result in serious injuries, e.g., crushing of limbs. Therefore, structural modifications may only be carried out with our prior approval and strictly in accordance with our instructions, particularly the information contained in these Assembly and Operating Instructions. Any further processing of the products which does not comply with their intended use is not permitted.

The end product manufacturer and fitter have to ensure that all the relevant current statutory, official and, in particular, EMC regulations are adhered to during utilisation of our products, especially with regard to end product manufacture, installation and customer advice.

## Safety instructions

The following safety instructions and warnings are intended to avert hazards and to prevent property damage and personal injury.

### Instructions for the user

#### General information

- The drive must be disconnected from its power source during cleaning and maintenance and when replacing parts.
- All work, including maintenance and cleaning, on electrical installations as well as other system parts must always be performed by trained technicians, in particular qualified electricians.
- Children from the age of 8 years and persons with reduced physical, sensory or mental capabilities or lack of experience and/or knowledge may use these devices, provided they are supervised or have been instructed in the safe use of the device, and have understood the hazards involved. Children must not play with the device.
- Systems have to be checked regularly by authorised specialists for wear and damage.
- Always put damaged systems out of operation immediately until they are repaired by an authorised specialist.
- Do not operate equipment if people or objects are within the danger zone.
- Observe the danger zone of the equipment during operation.
- Ensure that there is adequate clearance (at least 40 cm) between moving parts and adjacent objects.



#### Caution

#### Safety instructions for avoiding serious injuries.

- **Crushing or shearing points must be avoided or protected.**

### Instructions for installation and commissioning

#### General information

- Observe the safety instructions in IEC 60335-2-97. Please note that this list of safety instructions is not exhaustive, since it would be impossible for the standard to include all sources of danger. For example, the design of the operated product, the way the drive works in the situation it is installed in or even the way the end product is mounted in the end user's place of use cannot be taken into consideration by the drive manufacturer.

If any questions or uncertainties regarding the safety instructions contained in the standard arise, please contact the manufacturer of the part or end product in question.

- All applicable standards and regulations for electrical installation must be complied with.
- All work, including maintenance and cleaning, on electrical installations as well as other system parts must always be performed by trained technicians, in particular qualified electricians.
- Only use spare parts, tools and accessory devices which have been approved by the drive manufacturer.  
Unapproved third-party products or modifications to the system and its accessories represent a risk to

your safety and the safety of others. This means that the use of unapproved third-party products, or modifications which have not been agreed with or approved by us, are prohibited. We do not accept liability for damage or injury arising from such actions.

- Position switch with OFF presetting within sight of the driven product, but away from moving parts, at a height of over 1.5 m. This must not be publicly accessible.
- Permanently mounted control devices must be positioned where they can be seen.
- Rated torque and duty cycle must be suitable for the requirements of the driven product. Technical data - rated torque and service life can be found on the type plate of the tubular drive.
- Hazardous moving parts of the drive must be installed at a height of over 2.5 m above floor level or any other surface from which the drive can be accessed.
- To ensure safe operation of the system after commissioning, the limit positions must be correctly set/programmed in.
- Drives with a S05RN-F or 05RN-F connecting cable may be used both indoors and outdoors.
- To connect the drive to the driven part, solely mechanical accessory components made by the drive manufacturer from the current product catalogue may be used. The components must be installed in accordance with the manufacturer's instructions.
- If the drive is used for shading solutions in a specially marked area (e.g., escape routes, hazard zones, safety areas), compliance with all applicable regulations and standards must be ensured.



#### **Caution**

##### **Safety instructions for avoiding serious injuries.**

- **When electrical or electronic equipment and units are operated, certain components, e.g., the power supply unit, are live. Physical injuries or damage to property can result in the event of unauthorised interventions or failure to heed warnings.**
- **Be careful when touching the tubular drive, as it heats up during operation for technical reasons.**
- **Before installation, shut down all lines and control devices that are not essential for operation.**
- **Crushing or shearing points must be avoided or protected.**
- **When installing the drive, all-pole disconnection from the mains with a contact gap of at least 3 mm per pole must be provided (IEC 60335).**
- **If the mains connecting cable is damaged, it may only be replaced by the manufacturer. If the drive has a plug-in connecting cable, it must be replaced with the same type of mains connecting cable, which is available from the drive manufacturer.**

#### **Attention**

##### **Safety instructions for avoiding property damage.**

- **Ensure that there is adequate clearance between moving parts and adjacent objects.**
- **The drive must not be carried by the mains connecting cable.**
- **All latching connections and fastening screws on the brackets must be checked to ensure that they are secure.**
- **Ensure that nothing rubs against the tubular drive, such as shading solution attachments, screws, etc.**



## Intended use

The type of tubular drive described in these instructions is intended solely for the operation of roller shutters. This type of tubular drive supports not only curtain attachment by means of springs but also mechanical anti-lifting devices (e.g., Zurfluh-Feller, Simu, GAH Alberts and Deprat). These are detected automatically. If the springs or the top lath are not screwed or rivetted to the barrel, a point must be set in the lower limit position. For sunblinds, please use only the types of tubular drive designed for this purpose. This type of tubular drive is designed for use in single systems (one drive per barrel). The tubular drive must not be used in potentially explosive areas. The connecting cable is not suitable for transporting the drive. Always carry the drive by the housing tube. Other applications, uses and modifications are not permitted in order to protect the safety of the users and others, since these actions can impair the system's safety and carry the risk of personal injury and property damage. The drive manufacturer does not accept liability for damages or injury arising from such actions. Always observe the information in these instructions when operating or repairing the system. The drive manufacturer does not accept liability for damage or injury resulting from improper usage.

### Attention

**Only use anti-lifting devices if the roller shutter laths are sufficiently strong. The closed curtain must not project beyond the guide tracks or else there is a risk of the joint between the top two laths being subjected to excessive strain and getting damaged.**

## Assembling and disassembling the plug-in connecting cable

### Assembling the plug-in connecting cable

Insert the **dead** connecting cable into the drive head until the locating lug clicks into place in the drive. If necessary, use a suitable flathead screwdriver to assist with insertion. Set the screwdriver into one of the two plug grooves provided for this purpose. Check that the cable is properly engaged.

### C+plug

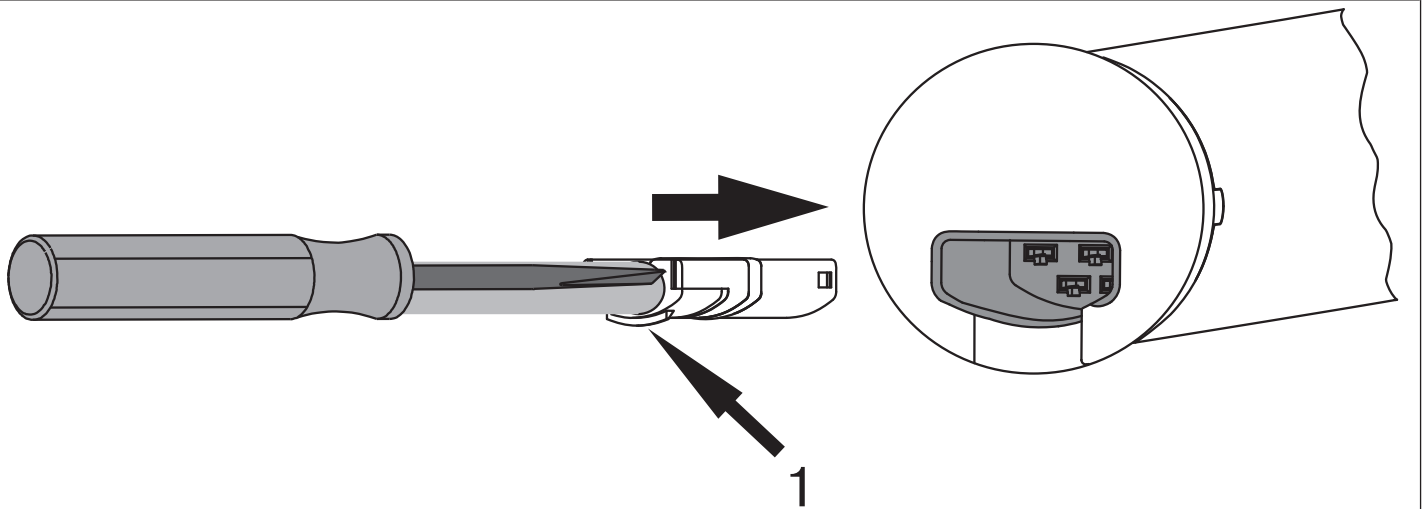

1 = locating lug

## Disassembling the plug-in connecting cable for tubular drives dia. 45 and dia. 58



### Caution

Prior to disassembly, the power supply to the connecting cable must be disconnected.

Insert a suitable flathead screwdriver right into the recess of the locating latch, so that the latch releases the locating lug from the plug.

Now you can pull out the connecting cable along with the flathead screwdriver.

dia. 45 and dia. 58

**C-plug**

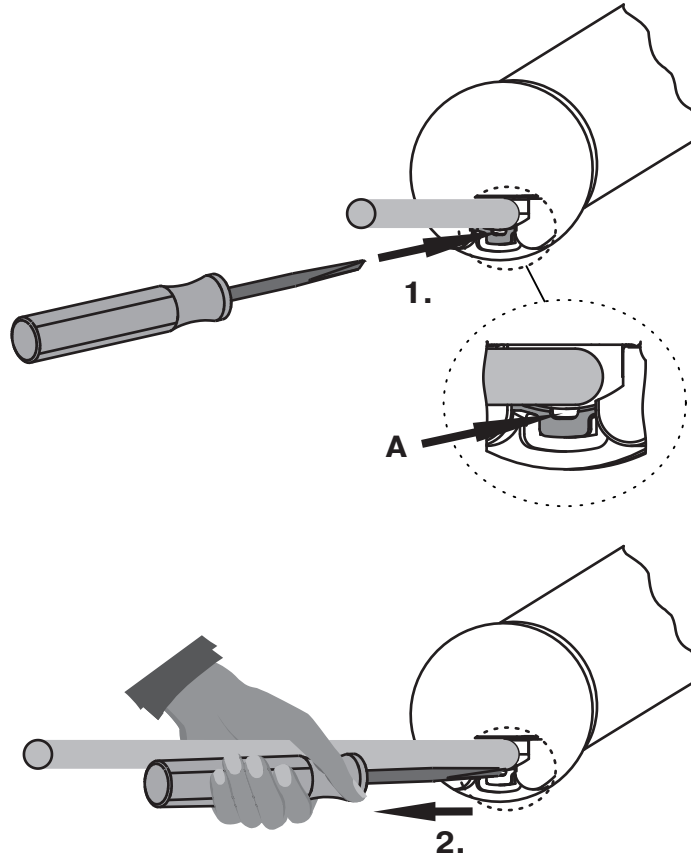

A = locating latch



## Installation

### Assembling the drive

#### Attention

To connect the drive to the driven part, solely mechanical accessory components made by the drive manufacturer from the current product catalogue may be used.

Prior to mounting, the fitter must ensure that the masonry and the system being motorised are sufficiently robust (drive torque plus weight of the shading solution).



#### Caution

Electrical connections may only be carried out by a qualified electrician. Prior to assembly, the power supply must be disconnected and secured. Please give the enclosed connection information to the responsible electrical contractor.

These drives cannot be operated with conventional switching elements (switches, timers and the like).

If you want the roller shutter curtain to open to the upper stop, proceed as follows: The roller shutter curtain must be prevented from being drawn into the shutter box with a mechanical stop or an angled end strip. With face-fixed elements, we recommend concealed stops in the guide tracks.

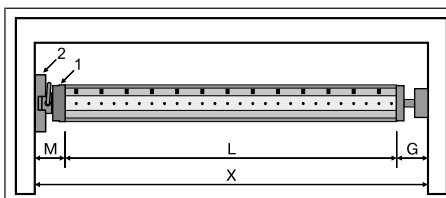

Calculate the space required at the side (M) by measuring the drive head (1) and wall bracket (2). The clear dimension of the box (X) minus the space required at the side (M) and idler (G) gives the length (L) of the barrel:  $L=X-M-G$ .

The space required at the side (M) varies depending on the combination of drive and wall bracket.

Then mount the wall bracket and idler. Ensure that the barrel is aligned at right angles to the wall and that sufficient axial play is allowed for the mounted system.

#### Attention

When using rigid shaft connectors, closed brackets must be fitted. The tubular drive presses the closed curtain down to make it difficult for people to reach under it or raise it. Only use curtains made of sufficiently strong material, such as aluminium, steel or wood. To prevent damage to the curtain it must run in guide tracks from top to bottom.

### Undoing the mounting pin

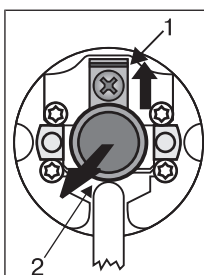

When pushed in, the mounting pin (2) locks automatically. To undo the mounting pin (2), push the tab washer (1) upwards and pull out the mounting pin (2).

### Drive adapter for obstacle detection



If you wish to use the "obstacle detection" function, you must use the "drive adapter for obstacle detection".



## Drive adapter safety catch

### Assembling the drive adapter with safety catch on the drive shaft

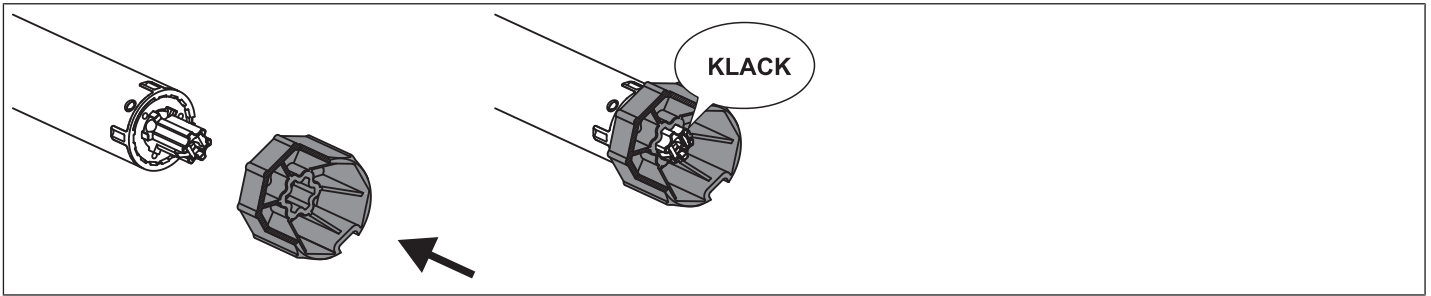

### Disassembling the drive adapter with safety catch on the drive shaft

Disassembly with disassembly tool, Item no. 4930 300 606 0

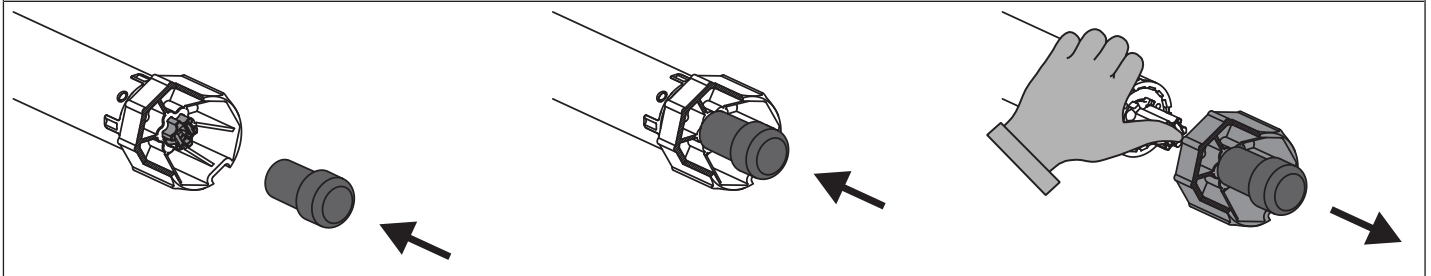

Disassembly with long nose pliers

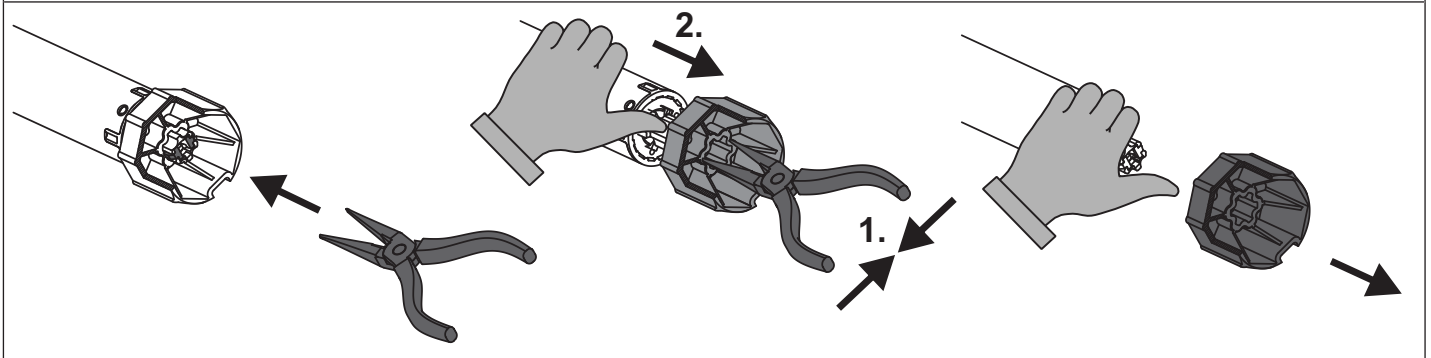

### Assembling and disassembling the drive adapter with separate drive adapter safety catch

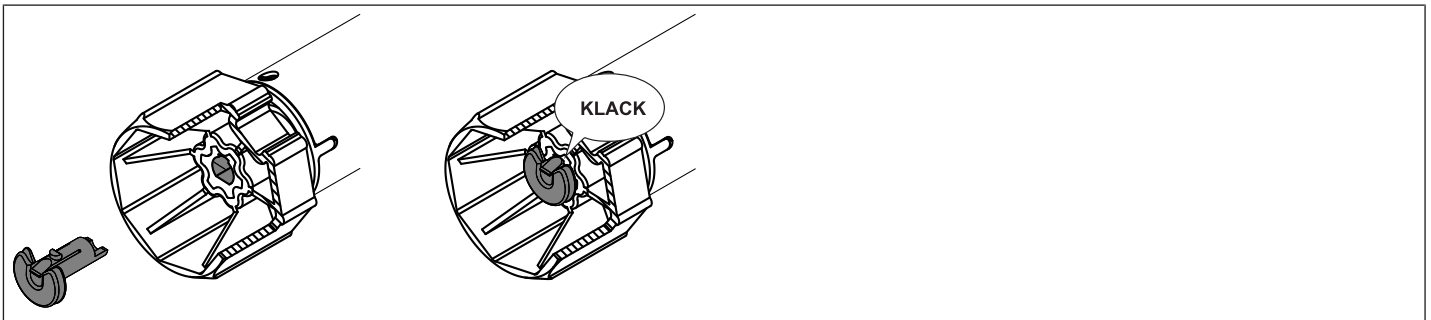

### Assembling and disassembling the drive adapter with screw connection

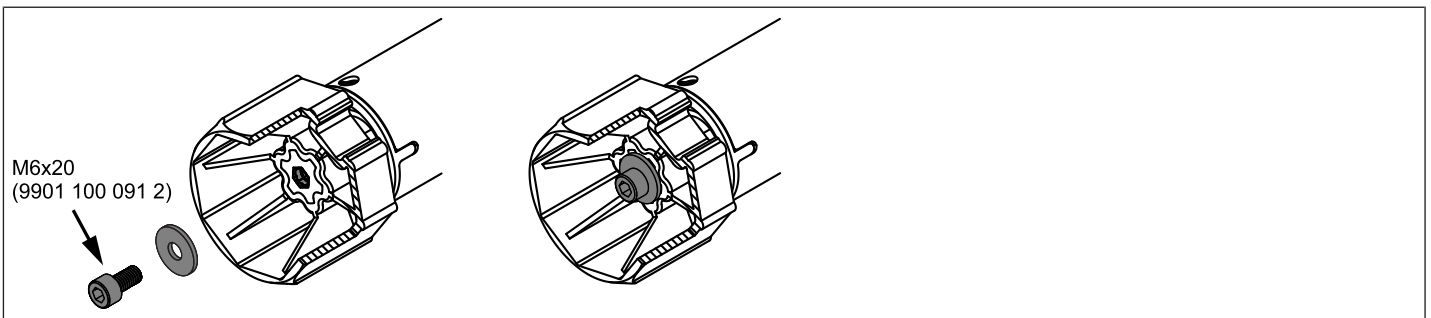

## Mounting the drive in the tube

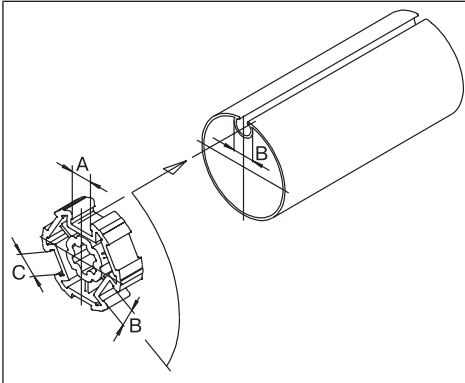

### For profile tubes:

In the case of some drive adapters, tolerances of the groove widths in different barrels can be offset by rotating the drive adapter into a different groove recess. These groove recesses have different sizes and allow the drive to fit exactly.

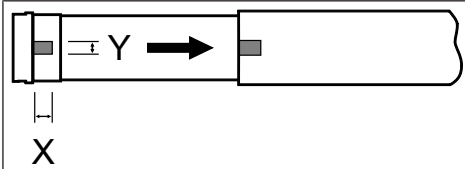

### For round shafts:

Measure the lug of the thrust ring (X, Y). Then notch the tube on the motor side, so the lug of the thrust ring can also be pushed into the shaft. There must be no play between the lug of the thrust ring and the shaft.

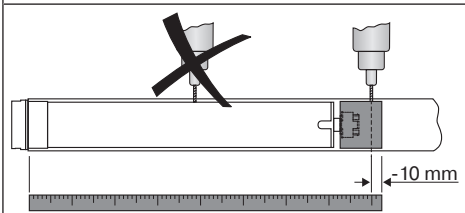

To ensure secure torque transmission for round shafts, we recommend screwing the drive adapter to the shaft (see the table below).

**Attention! When drilling into the barrel, never drill near the tubular drive!**

Size of drive [mm]	Drive adapter	Torque max. [Nm]	Fastening screws (4 units)
dia. 35-dia. 45	All	Up to 50	Self-tapping screw dia. 4.8 x 9.5 mm
dia. 58	Aluminium drive adapter	Up to 120	Countersunk screw M8 x 16 mm
dia. 58	diecast drive adapter	Up to 120	Self-tapping screw dia. 6.3 x 13 mm

We also recommend screwing the idler to the barrel.

### Attention

**Do not hammer the tubular drive into the tube or drop it into the barrel! The curtain can only be secured using springs or rigid shaft connectors. We recommend at least three pieces per metre of barrel.**

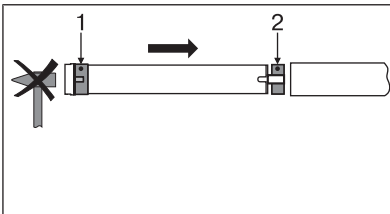

Assemble the tubular drive with the relevant ring (1) and drive adapter (2). If the ring has several grooves, select the groove which is a perfect fit and push the ring (1) onto the thrust ring.

Insert the tubular drive with the pre-assembled ring (1) and drive adapter (2) into the tube to achieve a form fit. Ensure that the ring and drive adapter are secure in the tube.

Mount the assembled unit comprising barrel, tubular drive and idler on the box and secure the drive with a split or spring pin according to the type of wall bracket fixing.

Position the barrel so that the roller shutter curtain can be attached with springs or fit the rigid shaft connectors in accordance with the manufacturer's instructions.

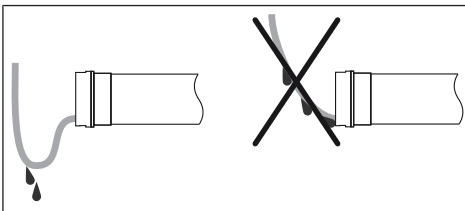

### Lay the connecting cable





Lay the connecting cable up to the tubular drive, and fix The connecting cable and any antennae must not project into the winding chamber. Cover any sharp edges.

## **Confirming the drive**

The drive confirms each programming and deletion action. The tubular drive does this through a small movement that can be perceived (audibly) as "clicking" or (visually) as "shifting".

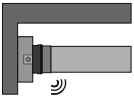
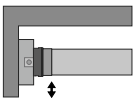
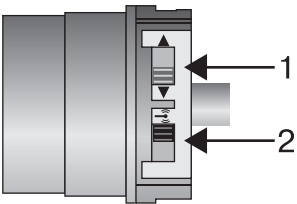

## First operation

Explanation of symbols	
	<b>UP button</b>
	<b>STOP button</b>
	<b>DOWN button</b>
	<b>Programming button</b>
	<b>The tubular drive clicks to confirm (One or more times)</b>
	<b>The tubular drive shifts to confirm (One or more times)</b>
	<b>1 = direction switch 2 = radio switch</b>

### Attention

The tubular drives are designed for short-time operation. An inbuilt thermal protection switch prevents overheating of the tubular drive. During commissioning (long drop distance or long running time), the thermoswitch may trigger. The drive will switch off. After a short cooling-down period, the system is ready for operation again. The drive does not achieve its full duty cycle until it has cooled to ambient temperature. Avoid a situation where the thermal protection switch cuts in repeatedly.

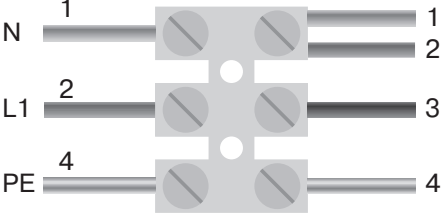
<p>230V AC / 50 Hz <span style="float: right;"></span></p> 	<p><b>Connecting the tubular drive</b> Connect the tubular drive to the power supply.</p>				
<table border="1" style="width: 100%;"> <tr> <td>1 = blue</td> <td>3 = black</td> </tr> <tr> <td>2 = brown</td> <td>4 = green-yellow</td> </tr> </table>	1 = blue	3 = black	2 = brown	4 = green-yellow	
1 = blue	3 = black				
2 = brown	4 = green-yellow				
	<p><b>Readying the tubular drive for programming</b> Readying the tubular drive for programming by switching on the power</p> <ul style="list-style-type: none"> <li>▶ Switch on the power.</li> <li>▶ The tubular drive is ready to programme for 3 minutes</li> </ul>				

**i** If several tubular drives are to be connected in parallel, you can deactivate the programming mode on one tubular drive by switching the radio switch to the outside position after turning the power on.

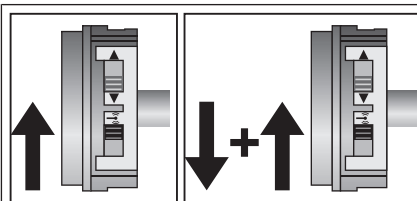

### Readying the tubular drive for programming with the radio switch

Switch the radio switch to the inside position. If the radio switch is already in this position, switch it to the outside and back to the inside position.

- ▶ The tubular drive is ready to programme for 3 minutes

### Programming the master transmitter

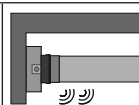

Press the programming button for 3 seconds when it is ready to programme.

- ▶ The tubular drive acknowledges.
- ▶ The programming process is now complete.



**If a transmitter is already programmed on the receiver, press the programming button for 10 seconds.**

### Checking that the running direction is correct

There are 2 ways to change the direction of rotation:

- Changing direction of rotation via rotation direction switch
- Changing direction of rotation via master transmitter

### Changing direction of rotation via rotation direction switch

Press the UP or DOWN button

- ▶ The shading solution runs in the desired direction
- ▶ The running direction is OK.

If the shading solution runs in the wrong direction, the running direction must be changed. Proceed as follows:

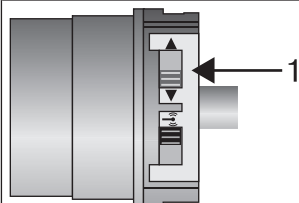

Switch the direction switch (1) to the opposite position.

- ▶ The running direction will now have changed.
- ▶ Check the running direction again.

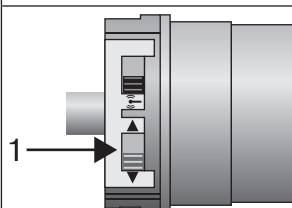

## Changing direction of rotation via master transmitter



**It is only possible to change the direction of rotation if no limit position has been set.**

Press the UP or DOWN button

- The shading solution runs in the desired direction.
- The running direction is OK.

If the shading solution runs in the wrong direction, the running direction must be changed. Proceed as follows:

		<p>First press the programming button and, within the next 3 seconds, press both the UP and DOWN buttons for 3 seconds.</p> <ul style="list-style-type: none"> <li>▸ The tubular drive acknowledges.</li> </ul> <p>Check the running direction again.</p>
--	--	---

## Intelligent installation management

### Limit position status indicator

A brief stopping and restarting indicates that no limit position has been set in that direction of movement.

### Completion of installation following automatic setting of limit positions

The drive saves the limit position permanently once the upper limit position is reached 3 times in succession. Installation is then complete. If the limit position is set above a point, this is stored permanently.

## Setting the limit positions



**The limit positions can only be set with the master transmitter. The shutter direction must be correct. When setting the limit positions, the tubular drive runs in dead-man mode with the limit position status indicator. The upper limit position must always be set first. When setting the upper limit position, ensure that the roller shutter curtain is not pulled out of the guide tracks.**

**When first installing using springs and adjusting the limit position "...to lower stop", the barrel in the lower limit position turns approx. 1/4 of a turn further than usual. In doing so, the tubular drive is able to automatically detect the use of anti-lifting devices or springs. The tubular drive switches off automatically.**

### Attention

**When operating the tubular drive without the drive adapter for obstacle detection, if using springs a point must be set in the lower limit position.**

## There are 4 ways to set the limit positions:

- Upper stop to lower stop
- Upper point to lower point
- Upper stop to lower point
- Upper point to lower stop

The limit position becomes fixed after the tubular drive has turned off **automatically** in the desired position three times.



### Upper stop to lower stop

	<p>Open to the permanent upper stop.</p> <ul style="list-style-type: none"> <li>▸ The tubular drive switches off automatically.</li> </ul>
	<p>Then close to the permanent lower stop.</p> <ul style="list-style-type: none"> <li>▸ The tubular drive switches off automatically.</li> <li>▸ The limit positions are now set.</li> </ul>

### Upper point to lower point



**There is no shading solution length adjustment with this limit position setting.**

▲	Open to the desired upper limit position.
● + ▲ 	Press the programming button and, within 3 seconds, also press the UP button and hold the two buttons down. ▷ The tubular drive acknowledges.
▼	Then close to the desired lower limit position.
● + ▼ 	Press the programming button and, within 3 seconds, also press the DOWN button and hold the two buttons down. ▷ The tubular drive acknowledges. ▶ The limit positions are now set.

### Upper stop to lower point

▲	Open to the permanent upper stop. ▷ The tubular drive switches off automatically.
▼	Then close to the desired lower limit position.
● + ▼ 	Press the programming button and, within 3 seconds, also press the DOWN button and hold the two buttons down. ▷ The tubular drive acknowledges. ▶ The limit positions are now set.

### Upper point to lower stop

▲	Open to the desired upper limit position.
● + ▲ 	Press the programming button and, within 3 seconds, also press the UP button and hold the two buttons down. ▷ The tubular drive acknowledges.
▼	Then close to the permanent lower stop. ▷ The tubular drive switches off automatically. ▶ The limit positions are now set.





## Changing the set limit positions



Once set, the limit positions can only be changed with the master transmitter.



### 1) Shortening the range of travel (the desired limit position is located inside the current range of travel)

	<p>Open/close to the desired new limit position.</p>
	<p>Press the programming button and, within 3 seconds, also press the DOWN button for the lower limit position or the UP button for the upper limit position and hold the two buttons down.</p> <ul style="list-style-type: none"> <li>▸ The tubular drive acknowledges.</li> <li>▸ The new limit position is now saved.</li> </ul>

### 2) Extending the range of travel (the desired limit position is located outside the current range of travel)

#### Attention

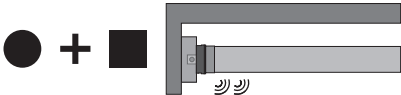
When both or individual limit positions are deleted, all the other set functions (intermediate position I, intermediate position II, upper anti-freeze mechanism, obstacle detection, run times, fly screen protection function) are deleted as well.

	<p>Open/close to the limit position in the direction in which you wish to extend the range of travel.</p>
	<p>Press the programming button and, within 3 seconds, also press the STOP button and hold the two buttons down for 10 seconds.</p> <ul style="list-style-type: none"> <li>▸ The tubular drive acknowledges.</li> <li>▸ The limit position is now deleted.</li> </ul>
	<p>Open/close to the desired new limit position.</p>
	<p>Press the programming button and, within 3 seconds, also press the DOWN button for the lower limit position or the UP button for the upper limit position and hold the two buttons down.</p> <ul style="list-style-type: none"> <li>▸ The tubular drive acknowledges.</li> <li>▸ The new limit position is now saved.</li> </ul>

## Deleting the limit positions

#### Attention

When both or individual limit positions are deleted, all the other set functions (intermediate position I, intermediate position II, upper anti-freeze mechanism, obstacle detection, run times, fly screen protection function) are deleted as well.



Once set, the limit positions can only be deleted with the master transmitter. Deleted limit positions are displayed on the limit position status indicator.

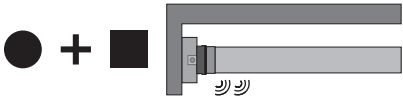

## Deleting individual limit positions

	<p>Open/close to the limit position to be deleted.</p>
	<p>Press the programming button and, within 3 seconds, also press the STOP button and hold the two buttons down for 10 seconds.</p> <ul style="list-style-type: none"> <li>▶ The tubular drive acknowledges.</li> <li>▶ The limit position is now deleted.</li> </ul>

## Deleting both limit positions

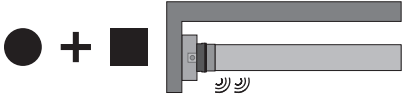

	<p>Open/close the shading solution to a point between the limit positions.</p>
	<p>Press the programming button and, within 3 seconds, also press the STOP button and hold the two buttons down for 10 seconds.</p> <ul style="list-style-type: none"> <li>▶ The tubular drive acknowledges.</li> <li>▶ The limit positions are now deleted.</li> </ul>

## Intermediate positions I + II



**The intermediate positions I + II are freely selectable positions for the shading solution between the two limit positions. Each travel button can be assigned one intermediate position. Both limit positions must be set before an intermediate position is set.**

## Setting the desired intermediate position

	<p>Open/close the shading solution to the desired intermediate position.</p>
	<p>Press the STOP button and, within 3 seconds, also press the desired travel button and hold the two buttons down.</p> <ul style="list-style-type: none"> <li>▶ The tubular drive acknowledges.</li> <li>▶ The intermediate position is now saved.</li> </ul>

## Travelling to the desired intermediate position

	<p>Press the travel button for the desired intermediate position twice within one second.</p> <ul style="list-style-type: none"> <li>▶ The curtain runs to the intermediate position assigned to the travel button.</li> </ul>
---	--





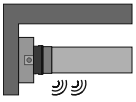
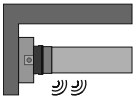

## Deleting the desired intermediate position

<p>2x▲ / 2x▼</p>		<p>Move the shading solution to the intermediate position that is to be deleted.</p>
<p>■+▲ / ■+▼</p>		<p>Now press the STOP button and, within 3 seconds, also press the travel button assigned to the intermediate position and hold the two buttons down.</p> <ul style="list-style-type: none"> <li>▷ The tubular drive acknowledges.</li> <li>▶ The intermediate position is now deleted.</li> </ul>

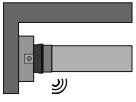
## Programming additional transmitters

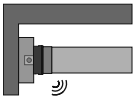

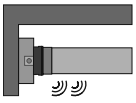

**i** In addition to the master transmitter, up to 15 further transmitters can be programmed in the tubular drive.

		<p>Press the programming button of the master transmitter for 3 seconds.</p> <ul style="list-style-type: none"> <li>▷ The tubular drive acknowledges.</li> </ul>
		<p>Now press the programming button of a new transmitter which has not yet been programmed in the tubular drive for 3 seconds. Doing so activates the programming mode of the tubular drive for a new transmitter for 3 minutes.</p> <ul style="list-style-type: none"> <li>▷ The tubular drive acknowledges.</li> </ul>
		<p>Now press the programming button of the new transmitter you wish to program again for 3 seconds.</p> <ul style="list-style-type: none"> <li>▷ The tubular drive acknowledges.</li> <li>▶ The new transmitter has now been programmed.</li> </ul>

## Deleting transmitters

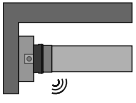
### Deleting individual transmitters

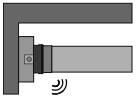
**i** The programmed master transmitter cannot be deleted. It can only be overwritten (see Programming the master transmitter [▶ 13]).

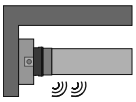
		<p>Press the programming button on the master transmitter for 3 seconds.</p> <ul style="list-style-type: none"> <li>▷ The tubular drive acknowledges.</li> </ul>
		<p>Now press the programming button of the transmitter to be deleted for 3 seconds.</p> <ul style="list-style-type: none"> <li>▷ The tubular drive acknowledges.</li> </ul>
		<p>Then press the programming button of the transmitter to be deleted again for 10 seconds.</p> <ul style="list-style-type: none"> <li>▷ The tubular drive acknowledges.</li> <li>▶ The transmitter is now deleted from the tubular drive.</li> </ul>

## Deleting all transmitters (except the master transmitter)

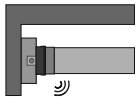
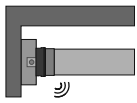
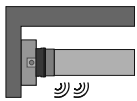
●		<p>Press the programming button on the master transmitter for 3 seconds.</p> <p>▷ The tubular drive acknowledges.</p>
●		<p>Re-press the programming button on the master transmitter for 3 seconds.</p> <p>▷ The tubular drive acknowledges.</p>
●		<p>Re-press the programming button on the master transmitter for 10 seconds.</p> <p>▷ The tubular drive acknowledges.</p> <p>▶ All transmitters (except the master transmitter) are now deleted from the receiver.</p>

## Overwriting the master

There are two ways to overwrite the master:

- Readyng the tubular drive for programming by switching on the power
- Readyng the tubular drive for programming with the radio switch

## Readyng the tubular drive for programming by switching on the power

**i** To ensure that the new master transmitter is programmed in the desired tubular drive only, all other tubular drives which are connected to the same power supply must be deactivated from the programming mode. To do so, after switching back on the power, execute a drive or stop command using the transmitter for the given tubular drives or switch the radio switch from inside to outside. If the radio switch is already in this position, switch it to the inside and back to the outside position.

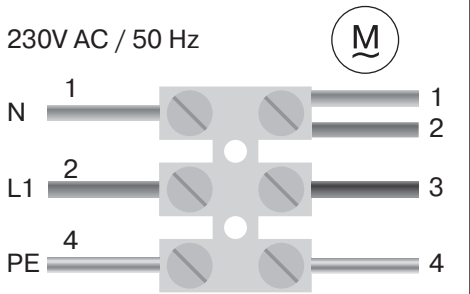
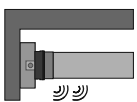
<p>230V AC / 50 Hz</p> 	<p>Switch off the tubular drive power for 5 seconds, then switch it back on.</p> <p>▷ The tubular drive is ready to program for 3 minutes.</p>				
<table border="1" style="width: 100%;"> <tr> <td>1 = blue</td> <td>3 = black</td> </tr> <tr> <td>2 = brown</td> <td>4 = green/yellow</td> </tr> </table>	1 = blue	3 = black	2 = brown	4 = green/yellow	
1 = blue	3 = black				
2 = brown	4 = green/yellow				
●		<p>Now press the programming button of the new master transmitter for 10 seconds.</p> <p>▷ The tubular drive acknowledges.</p> <p>▶ The new master transmitter has now been programmed and the old master transmitter overwritten.</p>			

## Readying the tubular drive for programming with the radio switch

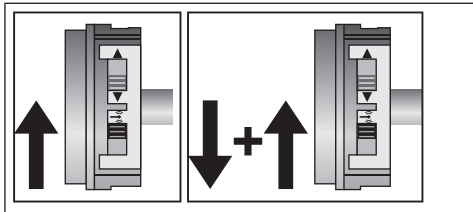
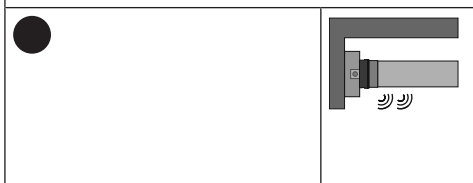
	<p>Switch the radio switch to the inside position. If the radio switch is already in this position, switch it to the outside and back to the inside position.</p> <ul style="list-style-type: none"><li>▸ The tubular drive is ready to program for 3 minutes.</li></ul>
	<p>Now press the programming button of the new master transmitter for 10 seconds.</p> <ul style="list-style-type: none"><li>▸ The tubular drive acknowledges.</li><li>▶ The new master transmitter has now been programmed and the old master transmitter overwritten.</li></ul>

## Local operation with a single button

### Wiring



**Only use a single button (normally open). Connect one button for each drive. The button must not be operated during the first five seconds after the mains voltage has been switched on.**

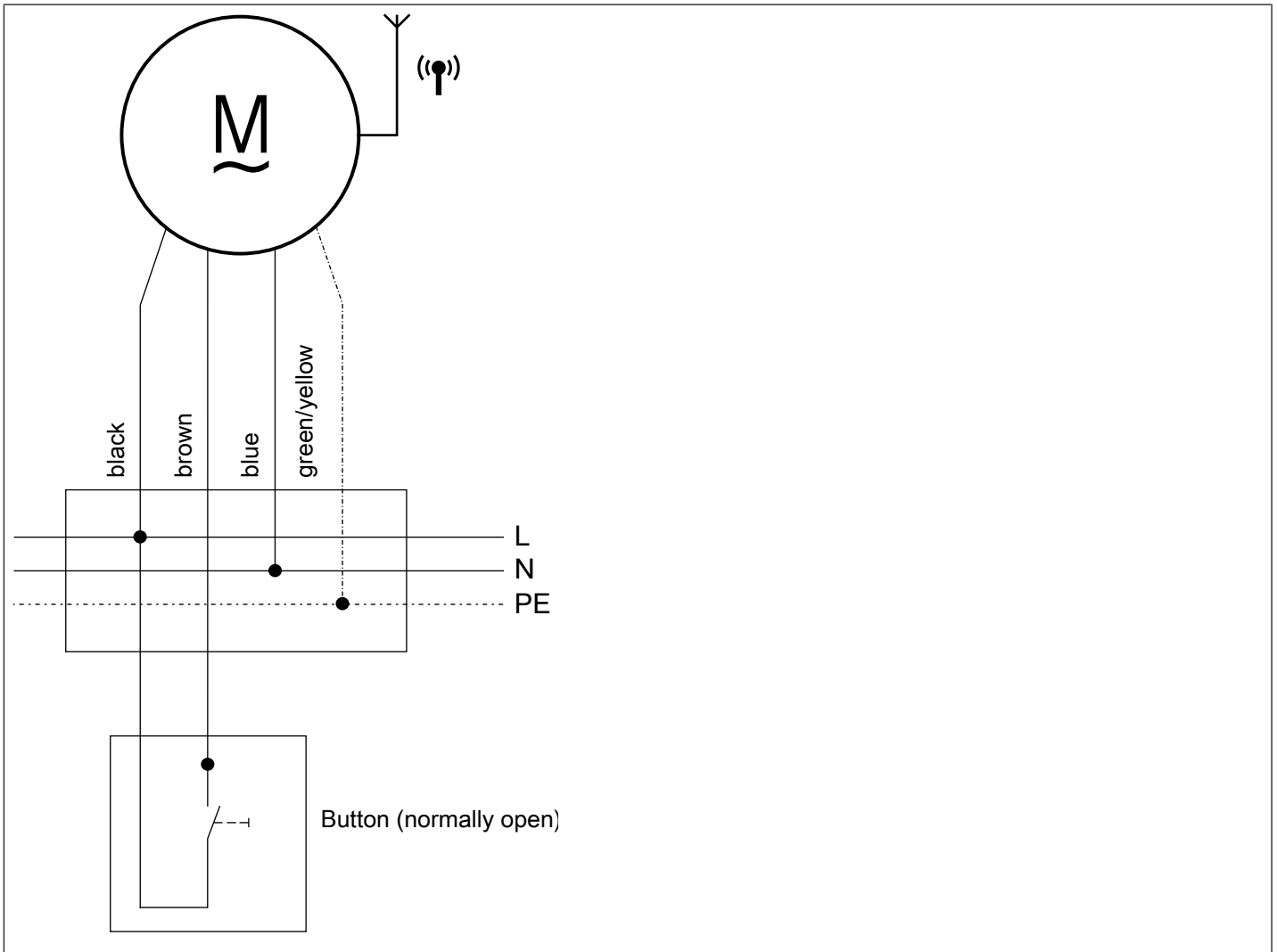

### Button commands

< 1 second	Moves in maintained operation
> 1 second	Moves in dead-man mode
Double-tap < 1 second	Moves to the intermediate position (in alternation if both are programmed)

Operation proceeds in this sequence: "Travel-Stop-Travel-in-the-opposite-direction-Stop".



## Upper anti-freeze mechanism



The upper anti-freeze mechanism helps to prevent the roller shutter from freezing in the upper limit position, as the roller shutter stops just before the upper stop. The distance from the upper stop is automatically cyclically checked and, if necessary, corrected.

The upper anti-freeze mechanism is deactivated on delivery.

Both limit positions must be set before the anti-freeze mechanism can be activated.

**i** The anti-freeze mechanism only works if a permanent stop is set at the upper limit position of the roller shutter. The anti-freeze mechanism is not visible until the shading solution has reached the upper stop from the lower limit position 3 times in succession.

### Activating/Deactivating upper anti-freeze mechanism

	Open the shading solution to the upper limit position.
	Then re-press the programming button and also the STOP and UP buttons for approx. 3 seconds. ▶ The tubular drive acknowledges.

## Obstacle detection

**Caution**  
**Obstacle detection is only active in conjunction with the "drive adapter for obstacle detection".**  
**In addition, please note that the drive must be pushed in to the shaft as far as the band of the thrust ring.**  
**Use of the drive's obstacle detection system as personal protection is not permitted. It has been designed exclusively to protect the roller shutters or sun protection system from being damaged.**

If the drive is correctly installed, it switches off when it detects obstructions or shutter faults and reverses a short way in the opposite direction and thus away from the obstacle.

If reversing is interrupted, a further drive command is only possible in the direction of reversing. Travel the shading solution without interruption until the tubular drive stops automatically. It is now possible to travel in both directions again.

The following are detected:

#### Moving DOWN

- A curtain jam when closing due to objects on the window sill or sticking of the lateral guide tracks.

**i** If the tubular drive switches off in the area of the upper limit position, it checks once more whether an obstacle is present.

To ensure complete closing of the roller shutter curtain at the lower limit position, the curtain does not reverse once it gets to approx. 360° from the lower limit position.

#### Moving UP

- Extremely large increase in the load (e.g., ice on the end strip)

To ensure that the roller shutter curtain safely enters the guide tracks, obstacle detection is inactive for approx. 1.5 revolutions of the barrel from the upper limit position.

## Fly screen protection function

If the fly screen protection function is activated, obstacle detection is activated after a revolution of the barrel of approx. 140° from the upper limit position. If the roller shutter curtain meets an opened fly screen door, the drive stops and returns to the upper limit position.

The fly screen protection function is deactivated on delivery.

Both limit positions must be set before the fly screen protection function can be activated.



**Obstacle detection is only active in conjunction with the “drive adapter for obstacle detection”.**

**When both or individual limit positions are deleted, this set function is deleted as well.**

### Activating/Deactivating the fly screen protection function

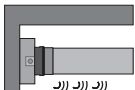
▲	Open the shading solution to the upper limit position.
● + ■ + ▼ 	Then re-press the programming button and also the STOP and UP buttons for approx. 3 seconds.  ▶ The tubular drive acknowledges.

## Disposal

This product is made of various materials which must be disposed of properly. Find out about the applicable regulations on recycling or disposal for this product in your country.

The packaging material must be disposed of properly.

## Maintenance

These drives are maintenance-free.

## Technical data dia. 45

Tubular drive	R12-17	R20-17	R30-17	R40-17
Model	C01a			
Type	CPROF+ A2			
Rated torque [Nm]	12	20	30	40
Output speed [rpm]	17	17	17	17
Limit switch range	64 revolutions			
Supply voltage	240 V AC / 50 Hz			
Connected load [W]	120	160	210	260
Rated current consumption [A]	0.50	0.70	0.95	1.10
Mode	S2 4 min			
Degree of protection	IP 44			
Min. tube inside diameter [mm]	47			
Frequency	915.3 MHz			
Emission sound pressure level [dB(A)]	≤ 70			



## Certificate of Suitability

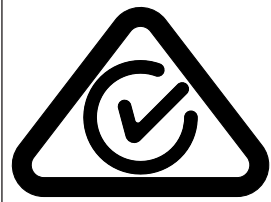

Certificate No.: SAA181406

### What to do if...?

Problem	Remedy
Tubular drive is not functioning.	Program new transmitter.
	Bring transmitter within range of the tubular drive.
	Press drive or stop button on transmitter at least 5 times in the immediate vicinity of the tubular drive.
	Insert batteries correctly or insert new batteries.
	Check electrical connection.
	Thermal protection switch in tubular drive has tripped. Wait until the thermal protection switch in the tubular drive is reactivated.
Shutter direction on tubular drive cannot be set.	Delete limit positions (see Deleting the limit positions [▶ 16]) and reset the shutter direction.
Incorrect shutter direction after deleting limit positions.	Change the shutter direction using the master transmitter or the direction switch on the tubular drive.
Tubular drive stops arbitrarily; cannot be restarted in the same direction.	Tubular drive has detected an increase in load. Briefly run the curtain in the opposite direction, then continue in the desired direction.
	Tubular drive is overloaded. Use a higher-torque tubular drive.
Switching times cannot be set on tubular drive.	Use transmitter with manual/auto slide switch.
Tubular drive does not operate at the set switching time.	Switch manual/auto slide switch to ☉.
	Switch the slide switch on one transmitter from ☽ to ☉. If the slide switch is already at ☉, switch it to ☽ and back to ☉.
Set switching times change.	Frequent 230 V AC power cuts.
	Fluctuations in the 50 Hz mains frequency.
	Use a "TimeControl" transmitter and set the desired switching time there.
During the programming run, the drive stops short of the limit position to be programmed.	For safety reasons, the drive reacts sensitively to sluggishness during the programming run, in order to prevent damage. Briefly run curtain DOWN and subsequently UP until you reach the upper limit position.
Ventilation slots of the roller shutter do not close fully.	Delete the limit positions (see Deleting the limit positions [▶ 16]) and set the limit positions as per "to lower point" (Setting the limit positions [▶ 14]); to this end, first programme the lower limit position (lower point) and then the upper limit position.



Sample wiring diagram

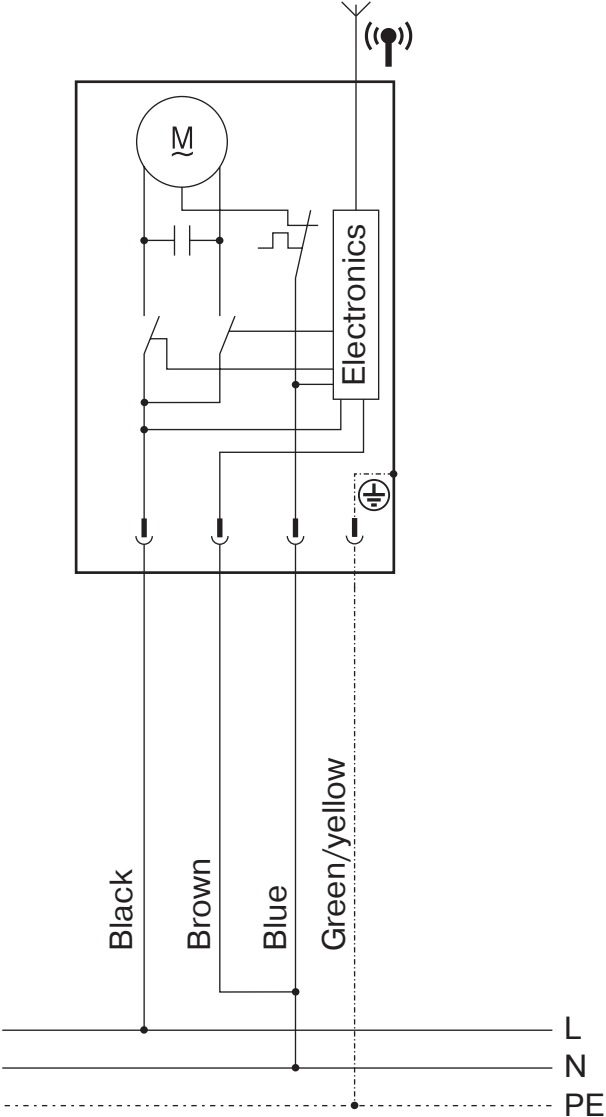







**BECKER**